

ISSN 2328-7144
DOI:10.17265/2328-7144

From Knowledge to Wisdom

Economics World

Volume 6, Number 4, July-Aug. 2018



David Publishing Company
www.davidpublisher.com

Economics World

Volume 6, Number 4, July-Aug. 2018 (Serial Number 29)



David Publishing Company
www.davidpublisher.com

Publication Information:

Economics World is published monthly in hard copy (ISSN 2328-7144) and online by David Publishing Company located at 616 Corporate Way, Suite 2-4876, Valley Cottage, NY 10989, USA.

Aims and Scope:

Economics World, a monthly professional academic journal, covers all sorts of researches on Economics Research, Macroeconomics, Microeconomics, International Economics, Labor Economics, Econometrics, Development Economics, Industry Economic, Regional Economic, Social Economic, Political Economy, Environmental Economics, Tourism Economics, Finance, Banking, Insurance, and other latest findings and achievements from experts and scholars all over the world.

Editorial Board Members:

Michael Ba Banutu-Gomez (USA), Iordanis Petsas (USA), Eduard Babulak (USA), Yutaka Kurihara (Japan), Tomoko Kishi (Japan), Ignacio Falgueras-Sorauren (Spain), Ralph Sonntag (Germany), Marcelo Miranda de Melo (Brazil), Graziella Benedetto (Italy), Ubaldo Comite (Italy), Celso José Costa Junior (Brasil), Krzysztof Piasecki (Poland), Domenico Marino (Italy), Karima Aly Korayem (Egypt), Juliana Leite (Brazil), Bonny TU (China)

Manuscripts and correspondence are invited for publication. You can submit your papers via Web Submission, or E-mail to economicsworld@davidpublishing.org, economics.world@hotmail.com. Submission guidelines and Web Submission system are available at <http://www.davidpublisher.com>.

Editorial Office:

616 Corporate Way, Suite 2-4876, Valley Cottage, NY 10989, USA
E-mail: economicsworld@davidpublishing.org; economics.world@hotmail.com

Copyright©2018 by David Publishing Company and individual contributors. All rights reserved. David Publishing Company holds the exclusive copyright of all the contents of this journal. In accordance with the international convention, no part of this journal may be reproduced or transmitted by any media or publishing organs (including various websites) without the written permission of the copyright holder. Otherwise, any conduct would be considered as the violation of the copyright. The contents of this journal are available for any citation, however, all the citations should be clearly indicated with the title of this journal, serial number and the name of the author.

Abstracted / Indexed in:

EBSCO, USA
Ulrich, USA
Cabell, USA
Summon Serials Solutions, USA
ProQuest
Google Scholar
Index Copernicus, Poland
Qualis/Capes Index, Brazil
GetCITED, Canada
CiteFactor, USA

Polish Scholarly Bibliography (PBN), Poland
Open Academic Journals Index (OAJI), Russia
NewJour, USA
InnoSpace, USA
Publicon Science Index, USA
Scholarsteer, USA
Turkish Education Index, Turkey
Universal Impact Factor, USA
WorldCat, USA

Subscription Information:

Price (per year): Print \$480
David Publishing Company, 616 Corporate Way, Suite 2-4876, Valley Cottage, NY 10989, USA
Tel: +1-323-984-7526, 323-410-1082 Fax: +1-323-984-7374, 323-908-0457
E-mail: order@davidpublishing.com
Digital Cooperative Company: www.bookan.com.cn



David Publishing Company
www.davidpublisher.com

Economics World

Volume 6, Number 4, July-Aug. 2018 (Serial Number 29)

Contents

- An Analysis of the Connection Between AI Development and the Creation of Games and Advanced Computer Systems** 251
Ewa Drabik
- Banking and Financial Intermediaries: Overlapping Evolving Monetary Functions and Investment Fallouts** 263
Mario Pines
- The Analysis of Dimensionless Magnitudes in Economic Science** 279
Odyseas Kopsidas
- The Impact of On-the-job Training on Job Mobility of Migrant Workers in China** 286
Jiang Jin-qi, Wang Zhen-hua, Chen Jing-wen
- Analysis of the Relationship Between GDP and FDI on the Economic Growth of Laos** 295
Thanet Wattanakul
- Analyzing the Roles of Agricultural Extension Agents in Hybrid Rice Technology Decision-Making Process of Farmers, Nay Pyi Taw, Myanmar** 303
Naing Kyi Win, Kyaw Kyaw Win, Cho Cho San, Nyein Nyein Htwe
- Local Government Asset Management: Affecting Factors and Policy Implications on Government Work Unit of Central Java Province in Indonesia** 314
Gregorius Nasiansenus Masdjojo, Ratna Sri Kumala Dewi
- Socio-economic and Socio-political Effects of Emigration on the Sending Countries** 325
Magdalena Bonev
- A Brief Analysis of Option Implied Volatility and Strategies** 331
Zhou Heng

An Analysis of the Connection Between AI Development and the Creation of Games and Advanced Computer Systems

Ewa Drabik

Warsaw University of Technology, Warsaw, Poland

Electronic games and video games have engaged the interest of artificial intelligence (AI) researchers. The cryptocurrency bitcoin is generated by an algorithm based on cryptography technology. High frequency trading (HFT) based on high quality software. The most spectacular games and programs use a learning neural network, for example backgammon, bridge, Go. Those were created with the use of “deep learning” on multiple layers of neural network. Sometimes, it is not clear “which path the computer will chose”. The paper aims at discussing the electronic version of some games and their applications in developing an AI.

Keywords: AI, Go, chess, video games, cryptocurrency, neural network

Introduction

Video games are derived from board games and various sports disciplines. Their mass production began in the 1970s. Their development has impacted technological advancement, and contributed to the design of ever more sophisticated algorithms based on neural networks (see <http://www.ai.c-labtech.net/sn/sneuro.html>) and genetic algorithms, mostly used in developing artificial intelligence (AI).

Gaming has engaged the interest of AI researchers almost from the very beginning. The first programs were notable for incorporating mechanisms enabling them to learn from experience. A stronger version was developed for the use of “genetic algorithms” and “evolutionary” computing. The culmination was the a famous chess game in 1997, the victory of Deep Blue over defending world champion Gary Kasparov in a widely publicized series of matches. Though some AI experts disparaged Deep Blue’s reliance on “brute force” computer applications (i.e., checkers, backgammon, poker, bridge, and Go). Intelligent “players” are the elements or participants in a variety of electronic games. It is very important that computers, for all their mathematical and other seemingly high-level intellectual abilities, have no emotions and feelings.

Electronic games and video games are presented in Chapter 2. Neural networks and genetic algorithms are presented in Chapter 3. Chapter 4 is concerned with games, such as Go and chess, specifically computer programs designed for playing those games with the use of AI. Chapter 5 attempts to find an answer, among others, to the question of whether the bitcoin cryptocurrency is best defined as money, commodity, or digital resource.

Ewa Drabik, professor, Faculty of Management, Warsaw University of Technology, Warsaw, Poland.
Correspondence concerning this article should be addressed to Ewa Drabik, Faculty of Management, Warsaw University of Technology, Narbutta 85, Warsaw 02-524, Poland.

Research Design

Research Subject

The paper aims at discussing the electronic versions of games, such as chess, middling poker, backgammon, bridge, and Go and their applications in developing an AI. Software designed for playing those games, such as AlphaGo-Zero (2017) can autonomously solve complex problems, which was never possible before. This shows great progress in AI development theory. Developing other video games, perhaps not as complex as the Go program, has also significantly contributed to the advancement of many AI-related disciplines, as well as human resources management, mastering techniques of eliminating opponents, or even education.

Theory and Hypotheses

Video games derived from social games, particularly board games and sports disciplines, have become the basis for designing increasingly complex and sophisticated software not only for the purpose of entertainment, but also education and problem-solving, and most importantly, perfecting AI development techniques.

The video game industry is also a huge market (over 70 billion USD in 2017), including also e-tournaments and e-sports which provide employment for a large number of programmers, managers, and similar professionals.

Video Games and the Related Market

A Short History of Video Games and Their Applications

A video game is a game played on the screen of an electronic device, such as a tablet, smartphone, computer, or a program which enables gameplay. Such games first need to be created, using computer code, and then of course sold. Their purpose can be entertainment, education, a logic, or agility based challenge for the player. Gamers have to perform tasks, such as solving problems, eliminating opponents, and competing with AI or with other players. Video games can run on personal computers, slot machines, game consoles, smartphones, TVs, and other platforms. They are derived from board games and various sports disciplines. Games became a mass product due to increasing popularity of consoles, computers, and slot machines in the 1970s.

Generally speaking, video game development progressed along with the development of computers. They were both agility based race games (e.g., “Need for Speed” and “Civilization”) and role-playing games, such as “Baldur’s Gate”. Other well known titles include “Prince of Persia”, “Quake”, “Tomb Raider”, and “Legend of Zelda”. The year 1999 marks the first appearance of tournament games, such as “Unreal Tournament”, “Counter Strike”, and “Quake III Arena”. The year 2000 marks a turning point for recreational games. The market saw some mixed genre titles and experiments, like “Shogun: Total War”. The 3D game environment was popularized by “Grand Theft Auto III”. In 2002-2006, highly interactive strategy games became increasingly popular (e.g. “Medal of Honor” and “Half Life”). In 2007, many titles premiered which are still popular today: “Assassin’s Creed”, “Mass Effect”, “Crisis”, or “The Witcher”. The years 2008-2012 were dominated by sequels; many popular titles got their new editions. The trend has shifted to independent (indie) games in 2013-2014. In that period, games were popularized by internet media (YouTube/Twitch). When it comes to online games, among the most popular were “Diablo” and “Starcraft”. A huge number of games were being created for a market with too little demand, which caused many small companies to face the perspective

of bankruptcy. In 2013, the Android system was released, which together with the growing popularity of smartphones caused another boom in video game production.

Video games have many applications. In the 1950s, they were used as training simulations for soldiers. They can also be applied to employee trainings improving competitive skills and modern management. Since the release of “Oregon Trail” in 1974, video games are also used for educational purposes. But primarily, just like the social games that precede them, they are a source of entertainment. A number of organized gaming competitions exist, such as “Poznań Game Arena” or “Intel Extreme Masters”, where the number of contestants in 2016 exceeded 110,000. There are also sports tournaments. An organization overseeing e-tournaments, “Cyberathlete Professional League”, was established in 1997 in Texas (USA). In the following years, other e-sports organizations appeared, such as “Turtle Entertainment GmbH”, “Word Cyber Games”, or “Major League Gaming”. The relatively young discipline that is e-sport faces similar issues as traditional sports (i.e., corruption, doping, and insolvency). E-sport players, similarly as their “traditional” counterparts, practice several hours a day to keep their skills sharp. This includes physical workout, in order to prepare the body for the exertion of a tournament! For particular games, sparring matches are played. In electronic tournaments, it is not the nationalities and names of the players that matter, but rather team membership and the “nicknames” that the players use in-game. Around 400 million people worldwide are e-sport fans. There is growing support for the idea of including an e-sport discipline for the first time during the 2024 Olympic Games in Paris. The games included in the Olympics would have to be free of violence: strategy and agility based, card games, football, etc. Globally, e-sport is evolving rapidly. Since 2013, the finals of the international e-tournament “Intel Extreme Masters” are held in Katowice (Poland). Famous teams, such as Manchester City—Paris Saint, Germain, Ajax Amsterdam, AS Roma, and Legia Warszawa have their own e-sport teams. Competitions and tournaments are one of the reasons why video games are a rather large branch of the global market. E-sport was worth around 500 million USD in 2016, and that value increases by 100-200 million annually.

Video Games as a Market Product and a Work of Art

Video games include music, images, and narration, which can all be art forms. There are video games that are considered classics. However, to consider a video game as a work of art is a controversial notion, one that has been debated since the late 1980s. In 1989, the Museum of the Moving Image in New York had an exhibition dedicated to games, such as “Hot Circuits: A Video Arcade”. This was met with a lot of criticism from many professional art critics and scientists who claimed, among other things, that video games cannot be considered art since they include a necessary element of competition and victory or failure. After all games, such as chess, Go, Pong, or Tetris can hardly be considered art. However, some claim that games featuring a plot and interesting visuals should be treated as a new genre of art and culture. Examples of such games include “Myst” (1999), “Bastion” (2011), “Ori and the Blind Forest” (2015), and “Hopy” (2017). These are usually simple adventure games or puzzle games with elaborate visuals and plot, for example, “The Talos Principle” (2014). Another reason for treating video games as an art form can be the fact that they can touch upon challenging topics, such as the meaning of life, the future, and its social consequences. Works in the video genre are typically dynamic, which brings in an element of surprise and enhances the narration.

The Distribution and Sales Models of Video Games

Polish game-makers have established their brand worldwide mainly due to titles, such as “The Witcher 3”, “Earth 2140”, “Dead Island”, “Call for Juarez”, and “Painkiller”. Rapidly growing companies, such as compact

disc (CD) Projekt, Techland, or City Interactive produce mostly games intended for smartphones, tablets, and browsers. In order to win over international markets, they create games with a high level of difficulty and long playthrough time.

In the 1980s, the most commonplace video game storage medium was a CD, however its capacity soon proved too small. Games began to appear on Digital Video Discs (DVDs), which were an optical storage medium like the CDs, except that due to increased storage density they had larger capacity. Initially, games could only be purchased in physical copies from stores. Starting in 2003, games began to be distributed over the Internet using the Steam platform. In this way, game producer could save money on DVDs, boxes, logistics etc. Some games are also available for free on the Internet; however, they usually include in-game content that is only made available after payment. It is also possible to play games for free in early access. This is a strategy of making games available at the early production stage. Money gained from early access is then used to further develop the game.

Europe Game Classification System

Pan European Game Information (PEGI) is a game classification system used in all of Europe. The tags provide information ensuring that the entertainment products, such as movies, videos, or games are appropriate for a given audience. For example, a game tagged as PEGI7 is appropriate for seven-year-old children, while a PEGI18 game is intended for adult audiences only. The PEGI tags also consider the themes included in the game. In order to obtain certification, a game distributor must prior to release fill out a questionnaire in which she outlines 37 points pertaining to the anticipated reactions of the users, as well assure that the game does not promote violence. Moreover, the game itself, along with the promotional materials, must be presented to the PEGI committee.

The Video Game Industry and Its Workforce

The video game industry employs traders, managers, marketing experts, programmers, beta testers, and game designers. A game designer is essentially a programmer who, in addition to coding skills, has extensive general knowledge in many fields. This is due to the fact that game-making requires a lot of interdisciplinary knowledge. For instance, graphics expertise is a must and this goes beyond simple computer visuals: One must know how lighting changes colors, be familiar with the physics of the Doppler effect, wave interference, shortest path algorithms, and even storytelling. An average game's source code is ca. 200-300k lines of code. Programmers are divided into specialized teams responsible for designing 3D models, graphics, screenplay etc. The creative process behind a game is so challenging that it can be safely claimed that games are particularly complex systems which share certain features associated with AI. Some of them, particularly interactive ones, such as Go and chess, have significantly contributed to the advancement of AI.

Due to their huge complexity, all games should be examined by testers. No large chunk of code is free of errors; they are virtually impossible to avoid. Contrary to popular opinion, a job that involves playing games all day long is not quite as pleasant as one might think. The work is very repetitive, and it requires a high level of concentration and attention to detail. A tester's job does not end at spotting errors. They also carry out black-box tests, which involve investigating what elements present a difficulty to players.

Another unavoidable part of game-making is the so-called "crunch phase". The term refers to the final stages of game production and the necessity to meet deadlines. Some companies introduce the role of line

manager, who is responsible for organizing the time, space and proper working conditions for programmers and testers alike.

Risks Associated With Games

It is not without reason that video games are divided into appropriate age categories: Some titles are safer to play for children and the elderly. There is a concern that gaming can cause increased aggression and often also addiction in the players. In December 2017, the World Health Organization (WHO) declared that the addiction to video games should be considered a mental illness. However, some psychiatrists specializing in addictions claim that video game addiction is a result of environmental factors rather than the games themselves. The risk of addiction is highest in people who have a tendency to lose themselves in a virtual world. Gamers are mostly young people, as shown in Table 1. The table shows the percentage of each age group within the gamer population.

Table 1

Gamers Age Groups in 2013 and 2015

Age group	2013 (%)	2015 (%)
15-24 years old	37	43
25-34 years old	33	32
35-44 years old	24	16
45-55 years old	5	9

Source: Cholerzyński (2017).

Most gamers are young people. Table 1 shows an increase in gamers above 45 years old, as well as those aged 15-24.

When it comes to the regions of the globe which are “dominated” by gamers, the largest gamer population and biggest turnover is associated with Asia and the Pacific. This might be a cause of global trends of rapid economic growth in Far East countries, China in particular. However, the largest increase in video game sales was observed in Latin America, as shown in Table 2.

Table 2

Turnover in USD on the Video Game Markets in (Particular) Regions of the Globe and Growth Compared to Preceding Year

Region	Market value	Annual growth (%)
Europe, Far East	23.5 billion USD	7.3
South America	4.1 billion USD	20.1
North America	25.4 billion USD	4.1
Asia and the Pacific	46.6 billion USD	10.7

Source: Newzoo Free (2016).

In 2016, the global game market was worth ca. 100 billion USD, with a growth of 8.5% compared to the previous year. It is undoubtedly a growing market. A superiority, weakness, opportunity, and threats (SWOT) analysis of the market suggests that its strengths are: genre variety, varied sales, distribution models, and the possibility of crowdfunding (financing the project by receiving donations from subscribers). Its weaknesses are: complex gaming jargon, the trend of viewing gaming in a negative light, concerns about health hazards, high difficulty for small game producers to succeed on the market, the uncertainty related to the sales, and reception

of a game. The opportunities are: the growing popularity of games, internet media popularizing the industry, an increase in popularity of social games, and growing diversity in price range. The main threats are: piracy, high competition when it comes to free-to-play games, customs barriers, and currently relatively low popularity of e-sport and other gaming events (Cholerzyński, 2017). A significant advancement in the production of games, particularly those based on board games, was due to the AI research.

AI, Genetic Algorithms, Neural Networks

Basic AI Terminology

Information processing in computers and similar devices occurs on appropriate representations of data. These can be letters, numbers, writing, images, electromagnetic signals, sound, signal chains, etc.

“Coding” refers to the process of assigning information to data according to established rules. A piece of information is assigned a corresponding string of characters (signals). The rules of assigning information are called a code. The same piece of information can be expressed using different data (i.e., represented by different code). A crucial role in information processing is played by algorithms.

- “Algorithms” are ordered strings of operations such that by following the steps, a specific goal will be achieved (e.g., solving a mathematical problem or a technical issue).
- “Continuous operations (analog)” are calculus, arithmetic operations on functions.
- “Discrete operations (digital)” are arithmetic and logical operations.

Every task can be described using bits of information (i.e., strings of ones and zeroes). When it was observed that any thought process can be described using ones and zeroes, the science of AI was established. The term was coined by John McCarty ca. 1955, defined as follows: AI is the science and engineering of making intelligent machines.

Currently, AI is considered a science dedicated to creating and studying intelligent behavior algorithms. It includes these of the programming methods which cause computer behavior similar to human thought. On the other hand, it is understood that human intelligence is the ability to recognize observed reality, to understand and establish goals, and seek means to achieve them.

The primary goal of AI is to accumulate knowledge (i.e., learn). Other major problems in AI are:

- (1) Decision making in conditions of incomplete data;
- (2) The analysis and synthesis of natural languages;
- (3) Logic based games such as chess and Go;
- (4) Expert and diagnostic systems.

The technologies used in industrial plants, which function in conditions of incomplete data, are also based on the same principles as AI. Automatic text translation is not on par with humans, but Google Translate is a constantly improving tool designed for this purpose. Neural networks have improved the functioning of processes, such as speech recognition, following verbal commands, and answering to queries. Algorithms make it possible to analyze images, stylize any photograph to look like the work of Van Gogh, Picasso or Munch, generate short poetic forms, compose, etc. Self-learning algorithms allow better care for health or value of provided services. The knowledge gathering process associated with AI is based on data exploration. For this purpose, both genetic algorithms and neural networks are used. AI is increasingly used in the power industry, in the creation of systems monitoring specific processes, in planning, and in decision-making. It is also used for image processing (e.g., in cameras), financial decisions support, and many other areas of everyday life. In

economy, there is a widespread use of expert systems that automatically assess (e.g., creditworthiness or best client profile) as well as plan marketing campaigns.

Genetic Algorithms

The theory of genetic algorithms was established based on analogical processes observed in natural evolution. Due to the mechanism of natural evolution, living organisms have reached an incredible level of complexity. Evolution occurs in chromosomes (i.e., genetic chains containing coded information about the given specimen). An important part of evolution is natural selection, which ensures that the only surviving organisms are those which increase the chances of processing and reproduction in a competitive environment. Evolution is based on the exchange of genetic material and on mutation.

The classic genetic algorithm K-AG operates on sets of zero-one chains. A single element of a chain is called a gene, while a whole chain is a chromosome. A set of chromosomes is called a population.

Outline of the K-AG algorithm is as follows:

(1) The starting population mechanism is based on the random formation of the desired number of chromosomes (coin toss, random number generator).

(2) The mechanism of quality assessment for a given chromosome is based on calculating the value of the fitness function. The purpose of this function is to state to what degree the chromosome can solve a problem.

(3) Chromosome selection is a mechanism based on selecting the chromosomes that will become the parents of next generations. The selection should proceed in such a way that the parent chromosomes have the highest possible value of the fitness function. The selection itself is random; however, the selection methods should be chosen in such a way that the high fitness chromosomes have the highest chances of being selected.

(4) The mechanism of mutation occurs on a single chromosome and changes its value.

(5) The crossover of chromosome pairs for the purpose of exchanging genetic material between chromosomes to create new specimens. This should create an improved new generation. The new generation may completely replace the old, from which only the lowest fitness specimens will be removed.

(6) Establishing a new generation. The newly generated children may: completely replace the old generation, replace its parents, and join the old generation with the exclusion of several (randomly selected) specimens.

(7) Assessment of the new generation based on the fitness function.

Major applications of genetic algorithms are:

- optimization of database queries;
- stock market value forecasts;
- extracting information from data;
- creating models of population migration;
- creating memory portraits etc.

Apart from genetic algorithms, another crucial role in creating an AI is played by neural networks.

Artificial Neural Networks

A neural network is an information processing system which utilizes the biological models of nervous systems. The history of neural networks begins in the mid-20th century. One of the first steps in the field was taken by Ada Byron (1815-1852) who built a primitive calculating machine and claimed to see no reason why machines should not be able to learn. It can be said that neural networks came into existence after the

publication of “A logical calculations of the ideas immanent in nervous activity” by McCulloch—Pitts in the *Bulletin of Mathematical Biophysics* in 1943. It is a model of binary inputs with a w_{ij} ($i, j = 1, n$) weight, with excitability threshold b_i , whose purpose is to determine what value of the weighted sum of the inputs should be achieved or exceeded. The neurons form a network which has the ability to learn. There are cellular, feedforward, multilayer, and recurrent networks. A cellular network is one in which each neuron is connected to the adjacent neurons. Feedforward networks are usually composed of several layers (see Figure 1); there are connections between neurons on different layers, but neurons on the same layer are not connected to each other.

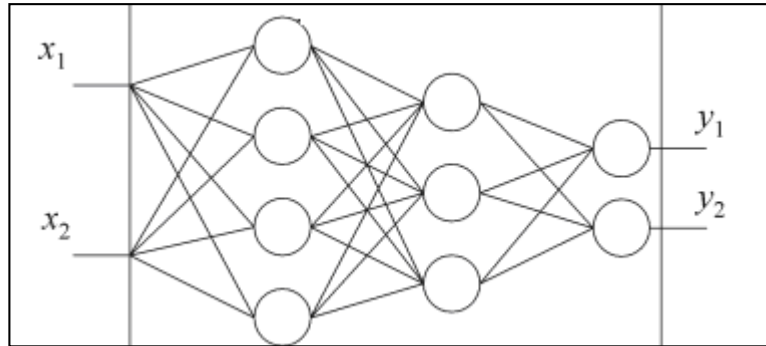

Figure 1. Visual representation of a multilayer neural network. Source: Own design based on illustration submitted to a website <http://www.ai.c-labtech.net/sn/sneuro.html>.

Figure 1 depicts an example multilayer neural network. A recurrent network is one in which part of the output signals are at the same time input signals. A network graph node corresponds to a single neuron. Its direction is from one neuron’s output to another neuron’s input. A layered neural network consists of: an input layer, hidden layers, and an output layer. The neurons are placed on layers so that there are no connections between neurons on the same layer. There are only connections between neurons placed on neighboring layers. The principle of a neuron’s operation is that a weighted sum of input values is used to measure excitability. The following designations are used:

$$\begin{aligned} X &= [x_1, x_2, \dots, x_n] \text{ learning vector,} \\ Y &= [y_1, y_2, \dots, y_M] \text{ output vector,} \\ D &= [d_1, d_2, \dots, d_M] \text{ desired response vector,} \\ W &= [w_1, w_2, \dots, w_n] \text{ weight vector.} \end{aligned}$$

Excitability is calculated in the following way:

$$h_i = \sum_{j=1}^n w_{ij} x_j + w_{i0} \quad (1)$$

where $w_{00} = 1$.

The output is created as a result of applying excitability to the output function, also called the activation function: $y_i = g(y_i)$,

The learning method of feedforward networks is the optimization of the goal function.

$$E(W) = \frac{1}{2} \sum_{k=1}^M (y_k - d_k)^2 \quad (2)$$

where M designates the number of neurons on the layer.

One of the methods of error minimization (2) in a neural network is to modify the weights (e.g., according to a growth algorithm and adjust them as necessary). In other words, the network “learns” by adjusting the weight values w_{ij} in iterations. The task of a training set is to present the network with cases that it might encounter during operation. All case classes should be represented in the given model of a neural network. A testing set is used to verify the network during and after the learning process. Throughout the learning process, the mean squared error should decrease. The learning procedure consists of modifying each neuron’s weight based on the error. If the goal is d and the actual result y , then the error is measured as $(d - y)^2$. The total error value for the whole network is calculated. The aim of the procedure is to adjust the weights to achieve the largest possible decrease in error. Neuron weights are modified, starting with the output neurons. This is called a backward propagation method. The weights can also be optimized using genetic algorithms. In this case, the weights are coded as a binary string (chromosome) and weight optimization is achieved by establishing a weight vector for which the fitness function (defined as a sum of squared errors) is the lowest. We differentiate between supervised learning, for example, the network compares the output with the known correct answer d_i , (return signal contains information about whether or not the output is correct), and unsupervised learning wherein the only available information is the correlations between input data. The network establishes categories based on those correlations and generates signals corresponding to specific categories. The following example illustrates in what way the weights are assigned.

Example. Input data consist of numbers. If input signals are 1, 1, 0, then the input vector is: $[1, 1, 0]^T$.

An artificial neuron assigns to each channel a separate number—a weight: $[2.5, -1, 0.5]$.

A number is generated based on the signal and the weights:

$$[1, 1, 0]^T \cdot [2.5, -1, 0.5] = 2.5 - 1 = 1.5$$

The output information is dependent on the total excitability value.

The procedure consists of generating 1 if it does not exceed a predefined threshold.

E.g., if excitability is 1.5, the neuron will generate 1.

Another basis for network learning is the dynamic interactions based on observing individual states, and implementing a strategy after which the network may receive a positive reinforcement (reward). The goal is to select a strategy in a way that maximizes the reward-defined metric of quality. The major applications of reinforcement learning are:

- optimal control;
- construction of self-learning robots;
- board games.

The most spectacular examples include using a learning neural network for playing trik-trak (backgammon) and Go. As a result of playing many games “against itself”, the network achieves mastery.

Designing a neural network consists of establishing its topology (i.e., setting the number of neurons on layers and the number of layers in the network). The next steps are: the preparation of a training set and a testing set, network learning, and verification of the results. Networks are usually approximators of a continuous function. They transform an n -dimensional set of input data into an M -dimensional set of output data.

It should be mentioned that to achieve text recognition with a neural network, one should use an alphanumeric code: $1 \rightarrow A, 2 \rightarrow B, 3 \rightarrow C \dots$ Both genetic algorithms and neural networks were used to beat

chess masters and Go master alike.

Chess, Go, and AI

Chess has served as a model for the creators of AI and has contributed to the development of computers with ever increasing computing power. Beginnings are often hard and such was the case with creating chess based programs (Drabik, 2017). In 1993, a computer “won” a match with the young chess master Judit Polgar. Another breakthrough turned out to be the multiprocessor computer called Deep Blue, which was able to use specialized chess processes to generate a position, evaluate its value, and analyze further moves. In February 1996 in Philadelphia, the computer lost in its first duel with Gari Kasparov. However, in May 1997, in New York, it managed to beat him. The fact is that its advantage was in enormous computing power and the ability to quickly access an extensive database. For the analysis of chess positions, it used a procedure called selective follow-up (alternative moves were investigated in a loop; if the position was judged to have a lower value the operation was interrupted and the program selected the move that it rated as having the highest value). Some computer technologies were based on Deep Blue’s experience, for example, Distributed Resource Management System (DRMS)—dynamic management of parallel environments and United Trace Environment (UTE)—universal rules for software running in parallel mode. In turn, parallel processing technologies are used in molecular dynamics, seismic analysis, meteorology, and business intelligence which include data mining, decision support, and knowledge management. In 2011, International Business Machine (IBM) also developed an intelligent computer capable of understanding human speech, called Watson. The machine can gather and search through a huge amount of information. It has won, among others, a duel with two champions of the American “Leopards” tournament. Now, a new generation of computers is being developed—quantum computers (i.e., ones that utilize a certain class of quantum phenomena). Those machines will be capable of autonomous decision making.

Go is one of the oldest games in the history of mankind. It was created in China in the years 2357-2255 BC. Go is a positional combinatorial game with zero-sum information. Go is a strategy game. The elements necessary for the game are: a square board with a grid of 19 intersecting lines and 360 pieces (called “stones”): 180 black and 180 white (Drabik, 2017). Go has contributed to the development of computer programs and AI. In 2016, a computer called Deep Mind using the AlphaGo program defeated a Go world champion, Lee Sedola from Korea (score 4:1). Deep Mind, after playing many games (in other words, after numerous optimizations) made a connection between bouncing a stone and collecting points.

In the recent years, AlphaGo was modified. This was done with the use of “deep learning” (unsupervised) on multiple layers of the neural network. The process is not pre-determined. Therefore, only the results can be observed; it is not clear “which path the computer will choose”. This method was used to create AlphaGo-Zero, which beat its predecessor, AlphaGo, in 2017. AlphaGo-Zero could learn from its mistakes. It can therefore be assumed that it has passed the cognitive threshold of a human mind! It may turn out that we have a self-aware machine which could lead humanity to new discoveries, or give humans eternal life. Consciousness is a particular mental condition which can be achieved. However, such an evolution would require thousands of years. For now, we can only regret the fact that AlphaGo-Zero has no notion of being a world champion.

Games on the Capital Market

The cryptocurrency bitcoin is an Internet-based means of payment independent of any country’s central

bank. Cryptocurrency can be generated by anyone with a network presence and access to significant computing power. New bitcoins are generated by an algorithm based on cryptography technology. The system presents a potential bitcoin buyer with a mathematical problem which she must solve! Solving the problem is not just a matter of skill, but also a fast machine. On average worldwide one bitcoin is generated every 10 minutes. The Chinese in particular are very proficient in their “production”. Every bitcoin is unique, its authenticity verified by the network. By the end of 2017 there were 16 million bitcoins. In theory, their production is to stop at 21 million.

The market price of a bitcoin is so high that we can assume that there is a speculative bubble emerging. This threatens with a crisis—not financial, but an energy crisis. The broadcast and maintenance of the system which supports the cryptocurrency consumes huge amounts of energy. A chance for cryptocurrencies lies with effectively “thinking” algorithms with some AI components. The managers of cryptocurrencies have a very extensive, multilayered marketing system. They are also well-versed in psycho-economy. They make covert offers inviting one to engage in a network of affiliated marketing (i.e., ads exchange system). They skillfully use certain psychological manipulation tools in order to entice potential gamers, who have a tendency towards “magical thinking”. This is accompanied by what is known as “confirmation bias”: the selective choice and interpretation of information so that it confirms the predefined expectations. The gamers are often confident in their own skill.

Binary options are another game generating a speculative bubble. It is a type of market hazard game where the aim is to bet on the behavior of the exchange rate of a currency, resource, stock, stock market index etc. in the immediate future (minutes or even seconds). It is also possible to bet on whether the rate will reach a certain limit. In this case the opponent is the broker-option issuer.

Similar mechanism is behind Forex (Foreign Exchange), an international currency exchange market, based on financial leverage. A trader works from her computer, buying and selling contracts for currencies or other financial instruments. An agreement assures that on the day when the contract is finalized the seller will pay the difference between the current value of the asset and its value on the day the contract was signed. If the difference is negative, it is the buyer who pays. There is a certain risk associated with the transactions and most of the information available is on the seller’s side. Thus the buyer is in danger of falling victim to the seller’s abuse, which is a classic example of a so-called moral hazard.

Playing on the capital market can result in huge losses for an independent investor. Transactions on a gigantic scale occur on the markets, mostly through complex computer systems. Any change on the market can cause rapid sales of financial instruments and a huge flow of capital, and the rules of the “game” are never symmetrical. Specially programmed, very fast computers generate more than a half of all transactions on the global markets. There were incidents (such as the 6th of May 2010) when stock prices begin falling rapidly and a billion dollars disappears from the market. After 20 minutes, everything is back to normal and most of the losses are recovered. The blame for these sudden price changes (flash crashes) is put on software. However, there is also a suspicion that the initial price drops were caused by an investor (or several) placing a large order. The computers have misinterpreted this as a sell-out signal and caused a temporary suspension of stock quotes and markdowns. This event has been recorded in the capital market history.

Computers take into account a great number of variables during decision making, including technical analysis results. A human can never keep up with all the data that needs to be analyzed. This is called high

frequency trading (HFT). The strategy is to make as many transactions as possible in a short time (e.g., in order to decrease the difference between purchasing price and selling price). Psychologist Daniel Kahneman, winner of Nobel Prize in economics, has pointed out that humans lose to machines ever more often.

Conclusions

The use of neural networks for video game production has become a breakthrough in AI research. Already in 1997, when Kasparov was losing a chess match against Deep Blue, he was competing against “the spirits of his predecessors” (chess masters). However, it was only in 2017 that the program AlphaGo-Zero has shown that a machine which can think independently thanks to neural networks is the true world champion at Go. The processing in networks occurs on many paths simultaneously, which means many operations can be carried out at once. It is however not the speed and processing power that guarantee that a computer will prevail over humans. An important advantage of neural networks is that they can discover patterns in data sets which for a human would be unclear or even invisible. Neural networks are highly adaptable, since unlike humans they can use data which is corrupt or even incorrect. They know how to approach data they’ve never encountered before. This is why they are being more and more widely used (e.g., to classify objects and images, reduce interference or make predictions in both methodological and economic modeling). Similarly, HFT based on high quality software is the future of the world economy. The asymmetry in qualities, such as processing speed spells failure to the future investors who would attempt to compete against the machine.

References

- Bobrowski, N., Rodzińska, P., & Socha, M. (2015). The condition of Polish line video games. Retrieved from http://www/kpt.krakow.pl/wp-content/uploads/2015/09/Raport_A4_Web.pdf
- Bomba, R. (2012). Gamification. What the reality stay cyber game? In A. Pitrus (Ed.), *The giant in shade: The video games in audio culture* (pp. 67-90). Cracow: Jagiellonian University Publishing House.
- Cholerzyński, R. (2017). An analysis and recommendation on the video games market in Poland (B.A. dissertation, Warsaw University of Technology).
- Drabik, E. (2016). Several remarks on the role of certain positional and social games in creation of the selected statistical and economic applications. *Foundations of Management*, 8(1), 289-296.
- Drabik, E. (2017). Reverse engineering, some board games as a key to the development of artificial intelligence and construction of economic models. *Economics Word*, 6(2), 121-132.
- Kwiatkowska, A. M. (2007). *The system of form further of decisions*. Warsaw: PWN.
- Newzoo Free. (2016). Global games market report. Retrieved from [http://resources.newzoo.com/hubs/Reports/Newzoo Free 2016/](http://resources.newzoo.com/hubs/Reports/Newzoo-Free-2016/)
- Ostrowski, K. (2016). The short stories of e-sport. Retrieved from <http://www.gram.pl/artykul/2016/02/09/krotka-historia-e-sportu-czyli-od-czego-sie-wszystko-zaczelo.shtml>
- Sieja, B. (2013, July). *The history about game* (2nd ed.). CD-Action, 92-93.



Banking and Financial Intermediaries: Overlapping Evolving Monetary Functions and Investment Fallouts

Mario Pines

University of Trieste, Trieste, Italy

Since the *New World Monetary Order*, as designed and promoted at Bretton Woods, several policies were considered. As proposed by Hansen, Harrod, and post Keynesian, after the 60 years and after the Bretton Woods final collapse, a new monetary framework has been overlapping gradually most of the world financial transactions. Separately from the single global financial markets, without previous patterns and insight experiences, the new global landscape is posing new deep challenges in the present monetary stalemate. The removal of the gold benchmark on the first day of WWI (First World War)—The serious *Gramm-Leach-Bliley Act 1999* repudiated the *Glass-Steagall Act*. The removal caused the colossal crisis as the time deposits and unlimited monetary base expansions produced effects never seen in modern history—A colossal surge of the financial instrument market indexes and financial bubble blowing erupted.

Keywords: monetary, multipliers, banking, intermediaries, market, prices, Central Banks' reserves

Introduction

Monetary Debasement and Elements of Intermediation

“Money will decide the fate of mankind, because individual liberty is only possible—or even thinkable—when confined within the boundaries of a collective discipline, calculated to curb the disorders that uncontrolled action is bound to provoke” (Rueff, 1964, p. IVX).

This sentence is to be connected to what Mundell said in his reconsideration of the 900 century monetary policies, formulated in his Nobel Prize ceremony message, in Stockholm in the year 1999 (Mundell, 1999).

One of the first questions arising in the Middle Ages first appearance of the deposit banks in the Florentine Renaissance was one single issue, the monetary function of the deposit banks. Further empowered by the Dutch *Wisselbank*, issuing bank's drafts, claimed by the city of Amsterdam, established in 1609, the precursor to, if not the first, modern Central Bank. In 1668, the *Riksdag*, Sweden's parliament, decided to found *Riksbanks Ständers Bank* (the Estates of the Realm Bank), which in 1867 received the name *Sveriges Riksbank* and started to refinance the commercial banks.

This question, related to the classification of banks' activities, is still pending now, and the solution leads to general macroeconomic wide and global consequences in a world with monetary masses expanding in uncontrollable quantities at the speed of light.

Mario Pines, professor, Department of Economics, Business, Mathematics, and Statistics (DEAMS), University of Trieste, Trieste, Italy.

Correspondence concerning this article should be addressed to Mario Pines, Department of Economics, Business, Mathematics, and Statistics (DEAMS), University of Trieste, Piazzale Europa 1, Trieste 34100, Italy.

The question became relevant by the appearance of the Dutch Wisselbank in the 17th century. The Wisselbank was a bank issuing drafts and allowing giro-accounts, and lately by the Riksbank in Stockholm introducing the fractional gold reserves monetary units, granting monetary credit and enabling monetary liabilities with purchasing power relying upon monetary deposits and bank credit, both progressively and partially surrogating legal tenderable currency bills.

Under fractional reserve banking, the flow of money instruments inverted its normal circuit: deposits started to stem mostly from the credit functions of both bank's deposits and credit, quantity multipliers. The leverage structure of the prevailing part of deposits and the monetary function of the bank's liabilities, turned upside down the classical bank image and representation and the monetary base became a smallest quantity.

There was a severance between intrinsic real value and monetary developments in a legal tenderable currency system: Instead of its intrinsic nature as money, the circulating monetary unit was better valued and understood through the Fisher exchange formula and its dynamics:

The chief purpose of the foregoing chapters is to set forth the causes determining the purchasing power of money. This purchasing power has been studied as the effect of five, and only five, groups of causes. The five groups are money, deposits, their velocities of circulation, and the volume of trade. These and their effects, prices, we saw to be connected by an equation called the equation of exchange, $MV + M'V = VQ$. (Fisher, 1911, p. 149)

The potential increase of money through Central Bank open market operations, is not negative by itself, if money is balanced by effective values acquired by the issuer; in the case of monetization of public debt, the problem lies with the "...way in which it is distributed" (Simmel, 1900; 2004, p. 172).

In the neoclassical framework, Gurley and Shaw, in the middle of the pseudo gold standard mechanism, retrieved in 1944 Bretton Woods, concluded that the rate of growth of money supply has neutral effects on the real variables in the economic world. They affirmed that there is no rational basis for choosing between alternative rates of growth of the money supply, as recollected since 1961 (Marty, 1961, pp. 56-62).

This question, related to the classification of bank activity and its regulation, is still pending, out of the Bretton Woods outcome and the answer leads to general macroeconomic, wide and global fallouts in a world with money circulating with the speed of light and swelling through the bank multipliers to levels not under control, blowing multiple bubbles. Improperly, banks have been authorized to operate as financial intermediaries and this wording has never been removed even from commercial banks afflicted by non-performing loans due to irresponsible moral hazard, adverse selection of loanable parties and taxpayers as final shock absorbers of last resort.

The primary function of intermediaries is to issue debt of their own, indirect debt, in soliciting loanable funds from surplus spending units, and to allocate these loanable funds among deficit units. The rise of intermediaries—of institutional savers and investors—does not affect at all the basic equalities in a complete social accounting system between budgetary deficits and surpluses, purchase and sale of loanable funds or accumulation of financial assets and debt. (Gurley & Shaw, 1955, p. 519)

The functions arise in the financial markets as considered by Gurley and Shaw themselves, according to a highly specialized formulation, indeed, the same authors used finally to define the function and types of intermediaries:

The principal function of financial intermediaries is to purchase primary securities from ultimate borrowers and to issue indirect debt for the portfolios of ultimate lenders. Although primary securities are their principal asset, financial

intermediaries also hold the indirect debt of other intermediaries and own tangible assets as well. Financial intermediaries may be divided into two main groups: the monetary system and nonmonetary intermediaries. The monetary system, in its intermediary role, purchases primary securities and creates money. Nonmonetary intermediaries, in contrast perform only the intermediary role of purchasing primary securities and creating nonmonetary claims on themselves, which take the form of savings deposits, shares, equities, and other obligations. (Gurley & Shaw, 1960, p. 192)

This strictly formal but relevant separation induces the same authors to articulate the financial markets classification according to the specific group of intermediary, as agents or as investors, with deep alternative corollaries and fallouts.

The 15 August 1971 formal termination of the pseudo, or quasi gold standard, as reintroduced in the Bretton Woods disputed July 1944 agreements, leaves a single currency as sole instrument of international liquidity, without a sound benchmark but an undisputable function, especially related to the oil revenues mostly denominated in dollars and deposited in London. The gold price, free to float on the global market, expressed the monetary related lost of purchasing power.

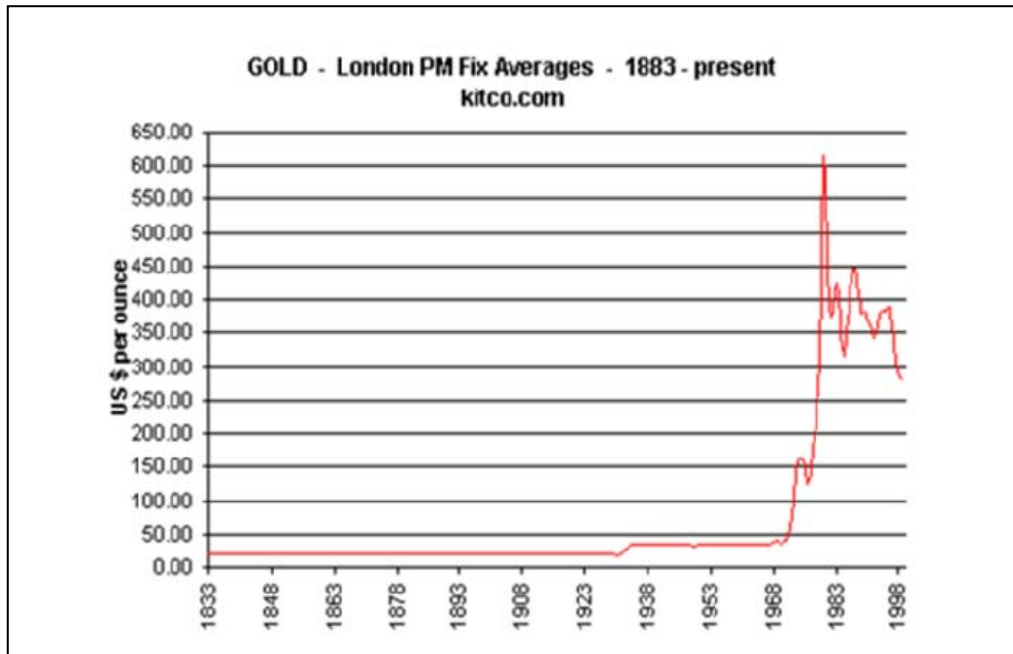

Figure 1. Gold price since August 1833.

Worse of all, the monetary quantity, after some decades of different unsuccessful alternative experiments, from the SDR (Special Drawing Rights), to the ECU (European Monetary Unit), and finally to the EURO, EMS (European Monetary System) agreements, after a stagflating decade, a bubble blowing high interest rates inflation recovery policy, erupted in 1987 in an endless monetary policy and dissolution of the interest rates balancing function, the system collapsed in an era of bursting bubbles, 1987, 1998, 2001, 2006, 2007, and 2008. The one way Abe-economics, deficit spending, and monetary policies as a standard global solution, left a growing percentage of the single unconvertible dollar as a last Noah's Arc on which all the other currencies, not able to support an international liquidity role, jumped on to find a temporarily monetary solution to the growing World trade imbalances and growing internal deficits. Therefore, the prevailing reserve supporting the currencies issuance ended to be the dollar up to 67% in the 2nd quarter 2017. However, the dollar is not as solid as the

Rock of Gibraltar, the greenback is part of a world monetary system that reflects a giant set of political unresolved conflicts and drawbacks. Given a choice, no one would design such a system. It is a big, rickety contraption held together with duct tape and glue. It is not pretty, but at present, it seems still intact.



Figure 2. Gold price since the dollar debasement.

Financial Profile of Chapters		
CHAPTER	FINANCIAL MARKETS	FINANCIAL INSTITUTIONS
II.	Market for money only, with emphasis on the demand for money.	Governmental monetary system composed of Policy Bureau and Banking Bureau.
III.	Markets for money and for one type of primary security.	Same as above.
IV.	Market for primary securities, with emphasis on growth in quantity and diversity of primary securities.	Same as above.
V.	Markets for money and for differentiated primary securities.	Same as above.
VI.	Markets for money, differentiated primary securities, and nonmonetary indirect assets.	Governmental monetary system and nonmonetary financial intermediaries (private and governmental).
VII.	Same as above, with emphasis on supply function of money.	Central bank, member commercial banks, nonmonetary financial intermediaries.

Figure 3. Financial profiles.

This very formal and scientific clear distinction between the different classes of very peculiar intermediaries suggest the same authors to propose an articulate deep analysis of different market's sections, according to different operators, called financial intermediaries (Gurley & Shaw, 1960, p. 6). The monetary function of nonmonetary intermediaries seems to prevail and intermediary's liabilities, unconditionally, bear the largest size in the monetary circuits as happened with the subprimes' lending, based more on expected collateral value increases, instead of expectations of cash flows from actual operational income.

The habitual image of a bank has always been that of a safe depositary institution, not supposed to involve itself in any kind of general risks, taking care of peoples' savings, transferring monetary claims, and acting as a basic guarantor of deferred purchasing power for futures savers' necessities. The common public image, furthermore, was that of a supplier of temporary credit necessities of commercial and industrial firms, related to working capital flows, firms producing income under strict risk monitoring rules. These peoples' deeply rooted opinions stem from a real benchmark currency, with an intrinsic stable value, linked to the underlying asset's benchmarks, generally called money and as a bank's deposit money, instantly always at hand for any spending necessity.

The bank deposit account is actually an irregular deposit: The bank issues a liability, acquiring the property of the money deposited, in order to avoid any client's involvement in both the economic result and the risk of its operations going on with his monetary asset, always assumed liquid, and promptly at hand, in case of a necessity.

After the irregular deposit, the bank is holding the full property of the money deposited and its actual readiness to satisfy its clients' requests is bound to the performance of the assets acquired appearing in its financial assets section.

The trust contract, on the contrary, according to the running juridical structure of general legislative frameworks, implies both a transfer of the property and all titles linked to the money trusted, to a third party. This is the very different case of the nonmonetary intermediary operations. A management agreement usually completes the scheme, where the principal empowers the trustee with investment strict guidelines, binding the bank or financial institution. Managing others people money from both a legal property point of view and a responsibility and risk sharing perspective, is the essence of a trust contract that never may affect or relate to a monetary intermediary like a commercial bank.

In the market economy, recurring cyclical fluctuations are generally due to the following hypotheses:

- factual concrete events, like the Californian earthquake that struck the coast of Northern California at 5:12 a.m. on April 18, 1906 and ignited a howling blaze that threatened total destruction of the city, or the strike against the two towers at the World Trade center on September 11, 2001. Otherwise, a constant pattern of planned investments without a riskless return, as capital and interests required to meet the amortization schedule in a sound loan, or in a covered hedge function, never leads to fluctuations, more easily connected to;
- propriety trading speculative assets, linked to the uncertain perspective of true optimistic managing investors, wrongly relying on future profits;
- credit allowed on a Ponzi scheme of roll over liabilities, in a growing intricate network that leads to the fatal financial fluctuations, when widely extended over a too gross layer of unproductive initiatives in a NPO (Not Performing Loans) final dead way condition.

With the first gold debasement, on July 31, 1914, due to the colossal equities sales orders coming from all over the world, in order to redeem the equivalent gold reserves from the issuing American banks started the new fiat money epoch and a four months closure of the NYE. The banking system was manifestly unable to

fully satisfy such requests in a regime of fractional reserves banking. The attempts to regain the gold convertibility were evident during the two World Wars aftermaths following efforts. The final weak pseudo convertibility, created and enacted by Harry Dexter White in Bretton Woods in July 1944, proposed the IMF (International Monetary Fund), the World Bank, and the GATT (General Agreement on Tariffs and Trade), new institutions guidelines. The international imbalance restoration was considered impossible, by two economists: the British Robert Triffin (1961) and the French Jacques Rueff (1971). Notwithstanding, the pillars of the new reestablished financial order in the Western world, most economies have fallen into a confused new era of stagflation, financial instability, bursting bubbles and monetary policies, with interest rates close to zero and in many cases even below zero. Finally, it was also tested and verified that, in a global economy, the Phillips and Taylor interest rates and employment curves are not able to explain and compose instable economy disequilibrium, both internal and external.

Consequences

After the three basic changes in the structure of the banking activity: Initially a depositary of means of payment, the new depositary functions, through irregular deposits and secondly, the issuance of liabilities, alternative to the legally or sound tenderable money. This profile became the rule in a fiat money system with Central Banks. At same time, as third step came the credit function, provided by banks, when conceding loans. This became the basic industrial revolution financial source and put the banks at the center of the financial market; initially as commercial banking sections of the financial market, discounting sound credits in the distribution area of firms with delayed revenues, or supplying working capital under the real bill doctrine.

In the sequent evolving years, the commercial banks became depositary institutions of savings and management trusts for entities with temporary excessive cash at hand. In any case, the title to the assets has always been transferred to the bank in an irregular type of deposit¹, becoming liabilities towards clients and as such entered in the bank' accounting system of formal debts, even if a pro tempore transfer of fungible property were running.

This plane set of relations requires the bank to run all the risks related to assets with corresponding liabilities, as much cautiously as possible. The clients always rely on their undisputable right of using their bank assets as currency, to meet their payment necessities trough any short of alternative circulating instruments, from drafts to bank orders, to checks to electronic transfer messages.

In order to substantiate this belief and actual capability, after the Great Panic of the 1907, on the 22 December 1913, both houses of Congress passed the *Federal Reserve Act*. Wilson signed it into law immediately. The act title was "An act to provide for the establishment of Federal Reserve Bank, to furnish an elastic currency, to effort means of rediscounting commercial paper, to establish a more effective supervision of banking...". After the roaring 20 years, without a gold restrain, in the booming stock exchange monetary growing indexes till the 1929 October crash, out of the gold standard, the Congress in the year 1933 passed the basic *Glass and Seagall Act*, regulations covering a raft of ills, fearing that a money trust was at the heart of market abuses. Under the *Glass and Seagall Act*, financial institutions were no longer allowed to take deposits

¹ A law dictionary, adapted to the constitution and laws of the United States. By John Bouvier. S.V. "Irregular deposit". Retrieved January 21 2018 from <https://legal-dictionary.thefreedictionary.com/Irregular+deposit>.

and underwrite securities offering, if not under a formal strict trust account under a fiduciary trust account².

Considering the small amount of legal tenderable residual currency in circulation, in the form of M0 (monetary base), statistically decreasing, less than 10% of total monetary banks' deposits, we can assume indisputable that most of the bank deposits, M1, M2, and the residual M3, at system level come as fallout from the credit originated by banks to third parties. The need of financial liquid assets, in a leveraging process, where credit precedes new deposits, generally a fallout of the banking credit activity itself, and the system's liquidity are the result of credit in a self-propelling process called leverage.

This premise related to the banking system globally considered, presumes the credit originates the deposits' growth, on the contrary of what looks in the single bank, where the credit utilized by the clients in first instance falls back on the same or some other bank of the system as deposit of the beneficiary. From a systematic point of view, therefore, credit creates deposits and the fact from a single bank point of view is always the opposite since banks lend what they receive from savers or liquid asset holder, clients holding assets received after the lending process of other banks of the system.

The potential spending monetary system's mass therefore, only in a very limited quantity is originated by the issuing banks as legal tender bills. It is called therefore monetary base, most of the paying instruments come instead from the banks' lending activity, a self-sustaining process without limits, as long as there is a demand of credit in the production sector and a monetary function of the commercial banks liabilities.

According to the first close analyst of the instability hypothesis (Minsky, 1992), after a long period of recurring monetary turbulences, the Keynes theories about the credit cycles and the government intervention through the monetary policies, seem to adhere to a close observation in both monetary gold standard and fiat money standard. If we compare the first major 1907 USA banking panic, faced with the *Aldrich-Vreeland Act* passed on May 27, 1908 enacting emergency currency issuance and the 1931-1933 deep bank holiday insolvencies, the first lies in natural events and partially on the trust banking activity failures. In the second case, the WWI (First World War) gold standard collapsed, with the emergency monetary issuance and the contextual closure of the New York stock exchange on 1 August 1914; the emergency monetary issues seem to have avoided a major economic depression also in this occurrence. The 1933-second depression really has no New Deal solution, both employment and exchange indexes never regained their previous level before the year 1954, after the WWII. Both recoveries come out of the fair public spending in new monetary denominations and values.

The modern crises, coming out of the gold parities dismissal, both real and pseudo or quasi, start definitively on 15 August 1971 with the Nixon statement about the temporarily gold conversion holdup.

After August 1971, a slow monetary erosion starts to confuse economists all over the Academia from unorthodox monetarists to Keynesians, from the gold base, to the bitcoin. The banking industry reforms seem contradictory, confused since the New Deal's strict separation between banking commercial orthodox functions, to the *Gramm-Leach-Bliley Act*, a *Clinton's Act of 1999* reform, inserting again the trust or the proprietary investment banking in an undecided shoreline between trust and banking activities. So, for an interrupted row of collapses of classical acquired values in the ethical consumer protection, to general wide panicking landscapes, through monetary bubbles inflated by the irresponsible deficit spending, often used to acquire electoral populism consensus.

² Trust account, business Dictionary.com, WebFinance, Inc. Retrieved from <http://www.businessdictionary.com/definition/trust-account.html> (accessed: January 17, 2018).

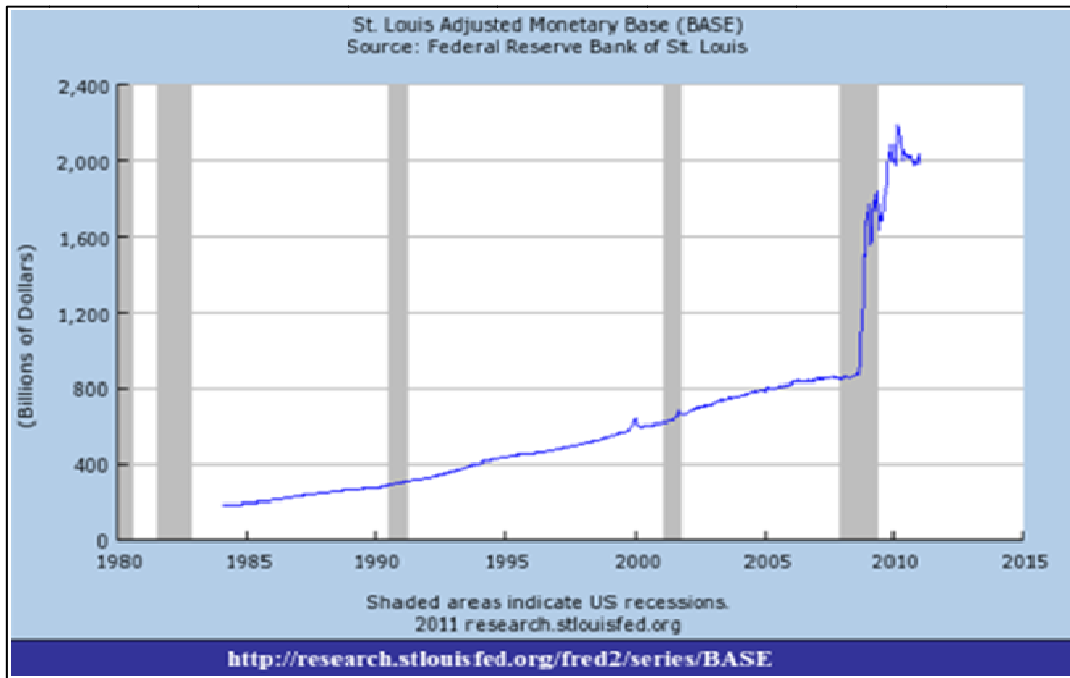

Figure 4. Monetary basis expansion in rescuing non-performing loans.

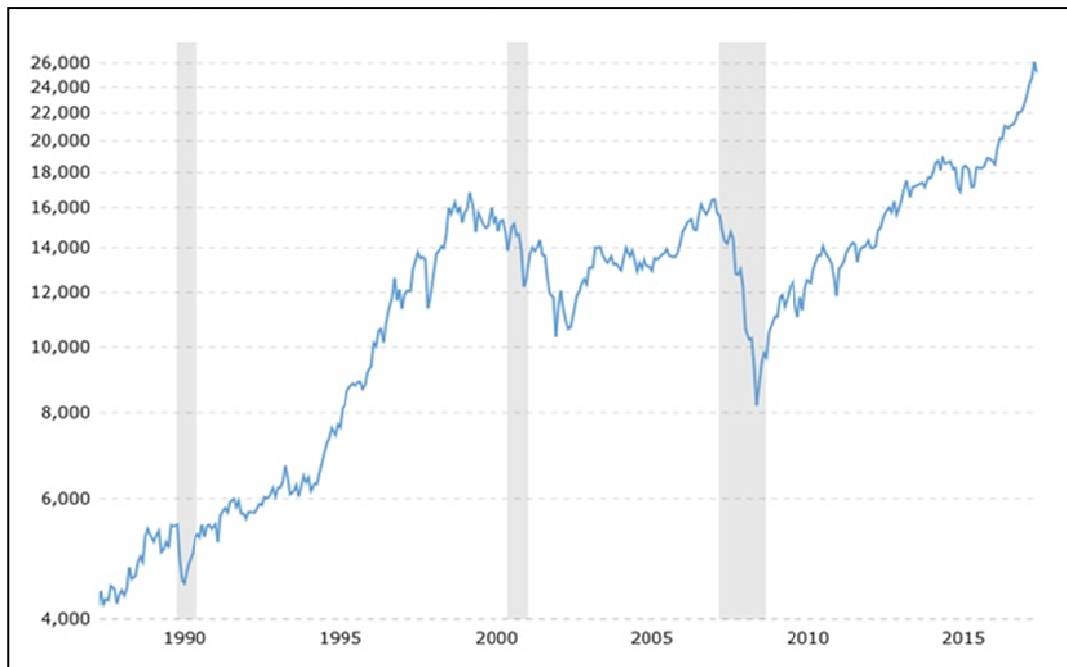

Figure 5. Dow Jones 1987-2015 (see <http://www.macrotrends.net/1319/dow-jones-100-year-historical-chart>).

Perspectives

According to this Keynes “veil of money”, the scope of countercyclical economic policy is radically curtailed in the new classical macroeconomics. In the case of rational probabilities, the monetary authority is not able to carry out systematic countercyclical economic policy, that is, it cannot exploit the existing short-run Phillips curve; it is different from the Quantity Theory of Money “veil of money”. The Quantity Theory “veil of money” has the trading exchanges in commodity markets are of goods for money and money for goods;

therefore, the exchanges are really of goods for goods. The Keynes veil implies that money reflects constantly financing terms through time. We can structure a part of the financing in the economy as dated payment commitments, in which banks are the central player. The money flows are first from depositors to banks and from banks to firms; then, later, from firms to banks and from banks to their depositors. Actually, in an almost banking monetary function system, all these processes are inversely running in real terms, the monetary base is the single quantity reflecting the third parties originate monetary flux, the remnant is pure bank leveraging trough the multiplier effect due to the fractional reserve lending capabilities. Initially, the exchanges are for the financing of investment, and subsequently, the exchanges fulfill the prior commitments, which are in the financing contract as original covenants.

In a Keynes “veil of money” world, the flow of money to firms is a response to expectations of future profits, and the flow of money from firms is self-financed by net profits that are realized. In the Keynes set up, the key economic exchanges take place because of negotiations between generic bankers and generic executives. The documents “on the table” in such negotiations detail the costs and profit expectations of the businesspersons, who interpret the numbers and the expectations as enthusiasts, bankers as skeptics.

Thus, in a capitalist economy the past, the present, and the future are linked not only by capital assets and labor force characteristics, but also by financial relations, the so-called IS-LM model, also known as the “Hicks-Hansen synthesis”. The IS-LM diagram claims to show the relationship between the investment-saving (IS) curve and the liquidity preference-money supply (LM) curve. The key financial relationship links the creation and the ownership of capital assets to the structure of financial relations and changes in this structure. Institutional complexity may result in several layers of intermediation between the ultimate owners of the communities’ wealth and the units that control and operate the communities’ wealth trough the leverage monetary multipliers. This perspective falls with the globalization of fiat money, unlimited potential supply of liquidity based by the legal tender alone as envisaged by Hansen (Hansen, 1953) but actually provided by the huge deficit spending, stemming out of Camp David August 1971 Nixon temporarily prophecy.

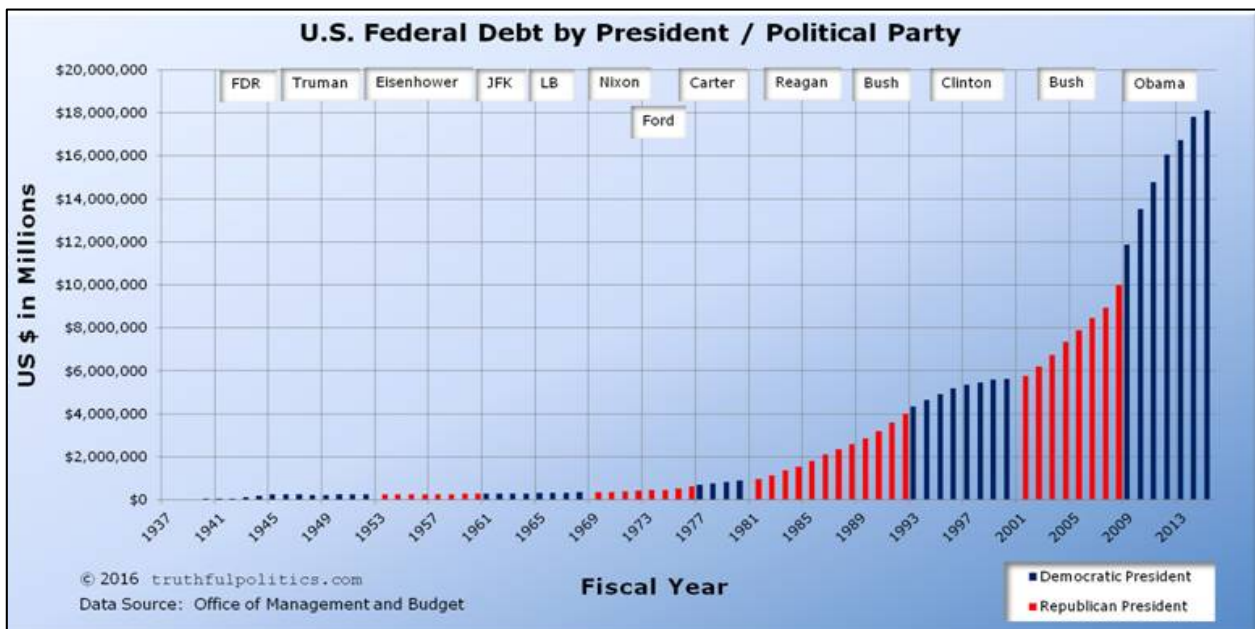

Figure 6. Federal debt growth in the years 1937-2015.

Expectations of business profits drive both the flow of financing contracts to business and the market price of existing financing contracts, therefore a financial inflation. Profit realizations determine whether the commitments in financial contracts are met, whether financial assets perform as the pro-forma indicated by the negotiations, whether finally there is enough quantity of idle money balances.

In the modern world, analyses of financial relations and their implications for system behavior cannot be restricted to the liability structure of businesses and the cash flows they entail. Households (by the way of their ability to borrow on credit cards for big ticket consumer) goods, such as automobiles, house purchases, and to carry financial assets, governments (with their large floating and funded debts) and international units (as a result of the internationalization of finance) have liabilities structures which the current performance of the economy either validates or invalidates.

An increasing complexity of the firms' financial structure, in connection with a greater involvement of governments as refinancing agents for financial institutions as well as ordinary business firms (both of which are marked characteristics of the modern world), may make the system behave differently than in earlier eras. In particular, the much greater participation of national governments in assuring that finance does not degenerate as in the 1929-1933 period, means that the down side vulnerability of aggregate profit flows has been much diminished. However, the same interventions may well induce a greater potential degree of upside (i.e., inflationary) bias to the economy.

In spite of the greater complexity of financial relations, the key determinant of system behavior remains the level of profits. The financial instability hypothesis incorporates the view of profits (Kalecky, 1965; Levy & David, 1983), in which the structure of aggregate demand determines profits. In the skeletal model, with highly simplified consumption behavior by receivers of profit incomes and wages, in each period aggregate profits equal aggregate investment. In a more complex (though still highly abstract) structure, aggregate profits match aggregate investment, plus the government deficit. Expectations of profits depend upon investment in the future, and realized profits are governed by investment; thus, whether or not liabilities are justified depends upon investment. Investment takes place now because businesspersons and their loaded bankers expect investment to take place in the future.

The financial instability hypothesis, therefore, is a theory of the impact of debt on system reactions and incorporates the manner in which debt is provided. In contrast to the orthodox Quantity Theory of money, the financial instability hypothesis takes banking seriously as a profit-seeking operator. Banks seek profits by financing activity and investment bankers. Like all entrepreneurs in a capitalist economy, bankers are aware that innovation assures profits. Thus, bankers (using the term generically for all intermediaries in finance, monetary and nonmonetary after the *Financial Modernization Act*), whether they be brokers or dealers, are merchants of debt who strive to innovate in the assets they acquire and the liabilities they sell. This innovative characteristic of banking and finance invalidates the fundamental presupposition of the orthodox Quantity Theory of money. There is an unchanging money growth item, out of the monetary function of non-banking intermediaries as well, whose flow is sufficiently close to being constant: hence, changes in this money's supply have a linear proportional relation to a current adverse choice theory in a full moral hazard hypothesis, with credit price level lately close to zero.

Three distinct income-debt relations for economic units, which are labeled as hedge, speculative, and Ponzi finance, can be identified and develop (Minsky, 1992, p. 7).

Trust Intermediaries

An investment bank is a nonmonetary financial intermediary that performs a variety of different services. Investment banks specialize in large and complex financial transactions, such as underwriting, acting as an intermediary between a securities issuer and the investing public, facilitating mergers and other corporate reorganizations, and acting as a broker and or financial adviser, generally for institutional clients.

Major investment banks included Barclays, BofA Merrill Lynch, Warburgs, Goldman Sachs, Deutsche Bank, Morgan, Morgan Stanley, Salomon Brothers, BS, Credit Suisse, Citibank and Lazard, Lehman Brothers. Some investment banks specialized in particular industry sectors. Many investment banks also had monetary intermediation retail operations that serve small, individual customers outside of a principal trustee contract at same time, within the *Financial Modernization 1999 Act*.

The advisory divisions of investment banks apply a fee for their services, while the trading divisions experience profit or loss based on their market performance on other people's money. Professionals who work for investment banks may have careers as financial advisers, traders, or salespeople. An investment banker career could have been very lucrative, but it typically came with long hours and significant stress and relative regard about others people's money. The bank, as a depositary institution, typically a commercial bank is normally an evolving firm that has a main function: the custody of monetary values underlying the fiat money scheme, generally an intrinsic quality of the instrument itself.

The three stages of the modern banking activity start from the Italian middle ages Florentine banks, as sometimes hindered in their evolution from the defaults of their main clients like King Edwards III of England and King Robert of Naples. Other times capable to imprint an age as the Medici left on the Renaissance, as depicted by Niccolò Machiavelli, in the area of commercial banking and issuing bills of exchange and further financing trade in the course of the Middle Ages. The Northern European Nations adopted the Florentine model but further implemented the circulation of multiple currencies, the pioneering of the checks and direct debiting and crediting; starting the gyro-account bank activities of scriptural currency transforming the bank debit in actual agreed currency. The first bank trying this new paying technology and exchange activities was the Wisselbank (Amsterdam Exchange Bank) in the year 1609 in an area with 14 different mints and copious quantities of foreign currencies.

In Stockholm, the foundation of the Stockholm Banco, the Riksbank was also designed to be a Lanebank, meaning that it engaged in lending as well as facilitating commercial payments. By lending amounts in excess of its metallic reserve, it had pioneered the practice of what would later become the fractional reserve banking, profitably lending money left on deposit as well as facilitating commercial payments.

The third step in banks' activity evolution comes in 1694 with the establishment of the Bank of England, aimed to assist the government's debt endorsed with distinctive privileges. Firstly, it was allowed to operate a partial monopoly on the issue of banknotes, a distinctive form of promissory notes that did not bear interest and allowed to perform transactions without current accounts.

Conclusions

The scenario on the international arena seems not to be much far since the one seen in 1944 in Bretton Woods, and the proof of the stalemate is the recurring presence of the IMF, the World Bank and the WTO (World Trade Organization) to try to absorb the locally instabilities and avoid spread panics in the banking sectors.

The debased currency has two unavoidable bad fallout effects, first the fiat money is a temporary instrument of payment or monetary exchanges in the short time market, it is not likely to permit any delaying expenses or saving functions as performed under both the gold or silver standards and lately the oil standard. Furthermore, it is short time financial transaction instrument, which allows and causes a market irrational exuberance. That is a financial instrument potentially inflation device, which have proved several times in the history the bubbles emotion, and the consequent spread wide banking panicking, as a fallout effect as well. The problem was seriously faced in the thirties through the credit separation. The *Glass and Steagall Act*, signed by President Roosevelt, that was actually the result of the November 1910 Jekyll Island Georgia, private bankers proposition, guided by J. P. Morgan, to activate a public clearing function and "...produced a design of a National Reserve Bank...Ironically, the Fed, one of the money trust that the Progressive feared, though President Woodrow Wilson, Treasury Secretary Carter Glass, and Democrats would later claim the credit for establishing the Fed" (Bruner & Carr, 2007, p. 145) which was at the base of the 1913 FED system activation.

The irregular juridical profile of the commercial banking activity, strictly separate from the trust or banking activity, whose joined activities may be confused in an intermediary function linked formally and legally to a management relationship. A formal mandate contract with the interposition of a principal and a trustee in a management account not to be considered as a liability of the agent. The positioning of the commercial banking activity within the intermediary hypothesis leads to a false concept of the banking activity itself overlapping financial instruments in the proper financial markets.

The full evidence of such a confused management hypothesis came out of the 1999 repudiation of the *Glass and Steagall Act*, signed by President Clinton under the proposal of Gramm-Leach-Bliley, Senators that de facto reintroduced the commercial-investment banking activity. The circumstance led to the dot.com, sub-prime, and derivatives bubbles, that were temporarily allocated Worldwide in negotiable financial instruments that, together with the gold pool were stock piled to inflate the huge internal public debt after the special TARP (Troubled Asset Relief Program) and all sort of similar EBC (European Central Bank) financial devices under a same prospective. The scope was to bailout over the contributors the losses linked to the improper management of the financial and industrial collapses in a concurring adverse selection and questionable moral hazard, at rate close to zero, an uncertain prospective for monetary savings, but only way out to absorb the liquidity and financial general shocks prospective.

This merchant, investment, trust-banking activities should never miss a specific client mandate and sole risking person to whom both profits and losses can be assigned. In a plane banking commercial relationship, the bank acquires the property of a fungible asset that becomes a liability to the client to be fully and constantly available as the transfer of this client credit allows the monetary function of commercial banks. Nonmonetary financial intermediaries cannot operate such role in any circumstance, as agents between the trusting creditor and the potential beneficiary.

The inclusion of huge amount of public debt within the Central bank's assets, to supply liquidity to the instable banking sector, is the main origin of leveraging. The sector had been increasing corresponding credit towards the state involved in restructuring processes, but has supplied monetary base M0 in a process of leveraging banking quantities, credit and as a fallout liabilities in a bubble spiral reaching first-time index values on financial markets, not reflecting actual parallel economic growth. The international monetary arrangement between the opposite Robert Triffin and Jacques Rueff visions of the impossible balance appears inserted in Harry Dexter White 96 pages agreement, as signed in July 1944 (Triffin, 1961; Rueff, 1964).

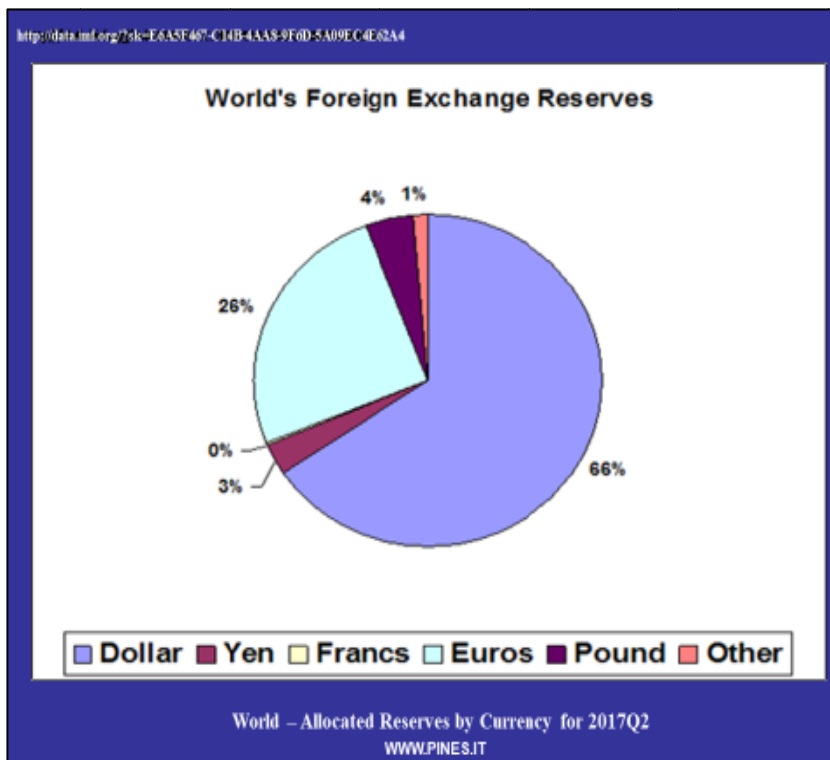
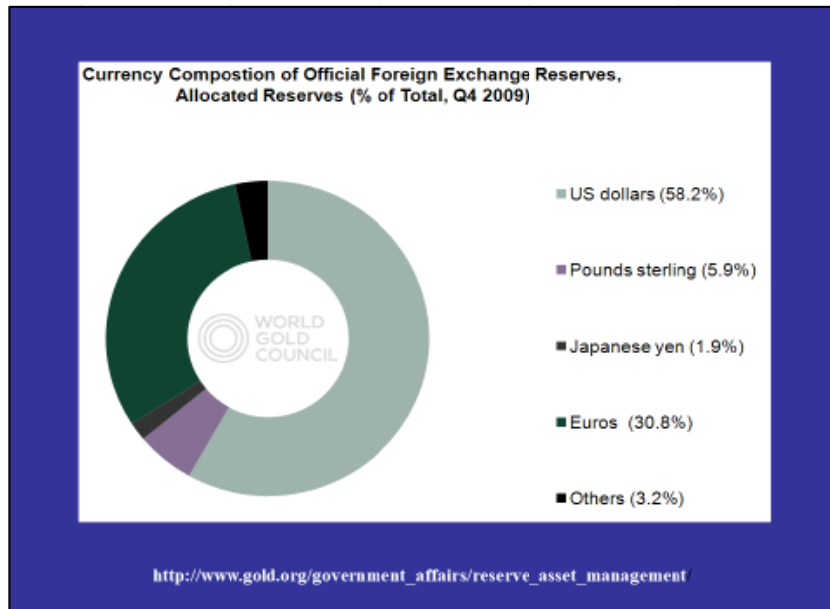

Figure 7. Central banks reserves.

The basic critic to the Bretton Woods, called Triffin dilemma (Triffin, 1961) was first in predicting a diverging gold base for a growing dollar monetary expansion, and an unrecoverable imbalance among international trade deficits. Furthermore, the surpluses would end without any automatic chance to restore a compensating price adjustment, as happened within the Hume gold exchange standard self-regulating mechanism. The three remedies adopted in Bretton Woods: the IMF interventions, the World Bank

restructuring financing projects and the WTO ex GATT trade clauses, are not solution presently efficient to reestablish some kind of equilibrium, as has happened in most of South American Countries and even in developed nations, not able to trust in new trade equilibriums.

On the other side, the monetary functions are performed by non-banking financial intermediaries and the banking role of the trust operations, without a clear-cut distinction between investment banks and commercial banks, the Demons of our own design (Bookstaber, 2007) have become actual consequences of the presumed financial innovation. It has become evident once more that after 50 years of efforts we have not resolved the debasement of the world currencies emptiness and sudden volatile foreign exchanges, direct as gold standards, indirect as quasi gold standard which have not been yet restored and the Noah's Arc only remaining currency has become doomed without solutions at hand.

The infringement of the borderline between the commercial and the investment banking has produced a powerful self-inflating huge monetary bubble, engulfed by the monetary policies of Central Banks. The unlimited debt bubbles both public as deficit spending and as well as private trough too large to fail theory and the recovery monetary programs within the social pressures and the crony monetary solutions to related problems, mostly aggravated by the Far East competition and the false financial indexes misrepresenting huge surge trough the exchange indexes.

The actual perspective, from a monetary point of view is very complex and leaves very little room to a likely short time solution to the international imbalances in a newly globalized World. Money in a theory of finance, as understood and clearly explained by Gurley in his study paper:

Close substitutes for money include time deposits in commercial banks, savings, and loan shares, mutual savings deposits, shares and deposits in credit unions, deposits in the Postal Savings System, policy reserves in private life insurance companies, and US Government savings bonds. There is, however, no hard and fast line between these financial assets and some others. (Gurley, 1960, p. 4)

The clear-cut money offer structure is linked to the global supply of legally tenderable money and quasi money under this precise Gurley's definition. The absence of a monetary instrument with a sound and reliable benchmark has two historic precedents, the gold standard and the oil standard, being oil the universal accessible lasting substance capable of saving, trading and easily convertible in currency universally therefore accepted. Nowadays, in the perspective of electric motion and shale substitute oil, gold has lost most of its appeal, and for the FED (The Federal Reserve Bank, USA), it will be a hard task to roll over indefinitely its colossal external debt denominated in dollars.

As long as nothing comes on the horizon as a valid substitute, the synthetic currencies, both as multilateral convention like the SDR or the ECU are not likely to substitute a structural material benchmark, nor a single country liability could hold a worldwide demand of international liquidity.

The growing mole of payment instruments will just blow bubbles without allowing a wise and necessary saving function in order to supply working capital to existing industrial structures and to allow the economic capital formation for new enterprises. From a USA point of view, the *Full Employment Act* created the Council of Economic Advisors that has been swindling between the supply side approaches up to the 21 trillion current deficit spending (*FED Act*, Section 13, point 3).

Table 1

Global Imbalance, Internal, and External Deficits in US\$ per 2 Q 2017

Country	Public debt	External debt	GDP	External debt /GDP	Public debt /GDP
USA	20,608,244,255,690	19,274,778,642,369	19,651,097,152,846	0.98085	1.04871
China	2,234,221,651,151	1,566,874,156,596	11,257,897,374,596	0.13918	0.19846
Japan	12,197,370,093,649	4,034,140,973,932	4,945,133,459,918	0.81578	2.46654
Germany	2,273,910,941,565	5,558,238,207,248	3,481,514,692,921	1.5965	0.65314
UK	2,447,269,514,237	7,078,976,647,543	2,630,807,435,537	2.6908	0.93024
France	2,507,135,062,469	5,569,101,039,779	2,467,807,435,538	2.2567	1.01594
India	1,229,046,988,741	409,609,428,548	2,269,933,103,617	0.18045	0.54145
Italy	2,510,776,395,873	2,719,301,869,506	1,851,628,673,230	1.4686	1.35598
Brazil	1,337,443,155,133	573,116,414,222	1,796,603,179,380	0.319	0.74443
Canada	1,524,995,239,334	1,726,182,545,418	1,530,982,301,923	1.1275	0.99609
Argentina	292,174,187,161	251,918,045,329	544,334,583,685	0.4628	0.53675
Australia	676,899,091,364	1,565,962,711,633	1,263,178,762,308	1.2397	0.53587
Belgium	509,000,345,629	1,416,923,093,545	466,937,911,862	3.0345	1.09008
Greece	356,221,168,251	584,882,109,232	194,603,929,207	3.0055	1.83049
Indonesia	360,915,764,696	331,935,605,365	934,187,789,500	0.35532	0.38634
Ireland	219,262,849,454	2,714,247,776,790	304,985,367,521	8.8996	0.71893
Korea	675,952,814,683	322,796,998,691	1,412,492,883,608	0.22853	0.47855
Mexico	610,662,832,623	500,151,695,406	1,047,942,873,857	0.47727	0.58273
Netherlands	459,388,385,649	4,078,586,110,588	778,148,225,777	5.2414	0.59036
Nigeria	79,572,729,521	36,211,881,773	405,140,709,689	0.089381	0.19641
Norway	162,616,561,067	161,928,734,852	370,741,431,079	0.43677	0.43863
Poland	258,267,236,345	383,271,935,265	469,115,353,870	0.81701	0.55054
Portugal	280,531,770,404	453,777,606,774	204,717,859,232	2.2166	1.37033
Russia	152,404,365,374	368,190,669,707	1,283,117,859,232	0.28695	0.11878
Saudi Arabia	250,873,831,278	224,665,092,471	658,455,722,364	0.3412	0.38100
Spain	1,294,917,345,099	2,360,919,321,939	1,234,532,170,016	1.9124	1.04891
Sweden	204,485,289,919	960,429,175,204	511,628,582,572	1.8772	0.39968
Switzerland	213,309,834,080	1,666,021,054,888	669,353,577,697	2.489	0.31868
Taiwan	176,509,180,270	198,621,883,513	529,898,576,722	0.37483	0.33310
Turkey	275,024,385,846	419,449,642,271	864,060,733,090	0.48544	0.31829
Total	56,379,403,266,555	67,511,211,070,395	66,030,979,712,394		

Source: <http://www.usdebtclock.org/world-debt-clock.html>, date 01/15, 2018.

The result has become currently the last World economy issue, the huge present monetary expansion, the leveraged Central Banks and the everlasting deflation. We can understand it, considering the financial markets price indexes explosion and the balancing decreasing industrial Asian Countries prices. These details allow a huge compensating deflating factor. The process is reliable as long as the external imbalances are supporting the internal deficits on a free choice basis or compulsory in the financial markets, under pressure of the monetary reserves suppliers (FED and BCE) which count over 92% of total Central Banks' reserves. The temporarily alternatives shows that there is no solution and that floating rates and new legal tenderable currencies, will not ever be able to reestablish a global Central Banks' reserves structures. Satisfying solution will not easily be ad hand unless a new currency has a benchmark and is not available to local monetary policies based on irretrievable deficit spending.

References

- Bookstaber, R. (2007). *A demon of our own design*. Hoboken, NJ: Wiley and Sons.
- Bruner, R. F., & Carr, D. S. (2007). *The panic of 1907*. Hoboken, NJ: Wiley and Sons.
- Ferguson, N. (2017). *The square and the town*. London, UK: History's Hidden Networks.
- Fisher, I. (1911). *The purchasing power of money*. New York, NY: Macmillan.
- Gurley, J. G. (1960). *Liquidity and financial institutions in postwar period*. Study Paper (No. 14), Joint Economic Committee, Washington.
- Gurley, J. G., & Shaw, E. S. (1955). Financial aspects of economic development. *The American Economic Review*, 45(4), 515-538.
- Gurley, J. G., & Shaw, E. S. (1960). *Money in a theory of finance*. Washington, D.C.: Brookings Institution.
- Hansen, A. (1953). *A guide to Keynes*. New York, NY: McGraw-Hill.
- Kalecki, M. (1965). *Theory of economic dynamics*. Retrieved from <http://www.levy.org/pubs/wp74.pdf>
- Levy, S. J., & David, A. (1983). *Profits and the future of American society*. Retrieved from <http://www.levy.org/pubs/wp74.pdf>
- Mackay, C. (1996). *Extraordinary popular delusions and the madness of crowds*. New York, NY: Harmony Books.
- Marty, A. L. (1961). Gurley and Shaw on money in a theory of finance. *Journal of Political Economy*, 69(1), 56-62. Retrieved from <http://www.jstor.org/stable/1829227>
- Minsky, P. H. (1992). *The financial instability hypothesis*. Working Papers (No. 74), Levy Economics Institute of Bard College. Retrieved from <http://www.levyinstitute.org>
- Mundell, R. (1999). *A reconsideration of the twentieth century*. Retrieved from <http://www.columbia.edu/~ram15/nobelLecture.html>
- Rueff, J. (1964). *The age of inflation*. Chicago: Regnery.
- Rueff, J. (1971). *The monetary sin of the west*. New York, NY: MacMillan
- Shiller, R. J. (2005). *Irrational exuberance*. Princeton, NJ: Princeton University Press.
- Simmel, G. (1900; 2004). *The philosophy of money*. Lipzig, New York, NY: Routledge.
- Triffin, R. (1961). *The gold and the dollar crisis*. New Haven: Yale University Press.

The Analysis of Dimensionless Magnitudes in Economic Science

Odysseas Kopsidas

University of Piraeus, Piraeus, Greece

An economy consists of the economic system of a country or other unit of human society. It includes labor, capital, natural resources, production, trade, distribution and consumption of goods and services in the area where human society is active. These factors give context, content, and determine the conditions and parameters with which the economy operates. When searching with data mining techniques to identify or find out dimensionless groups (DGs) in technical literature, it is possible to meet errors/faults/omissions concerning both, the form and the content of such groups. In the present study, a methodological framework has been developed in terms of a logical flow chart, including 11 activity stages and seven decision nodes, to acquire/process/store/retrieve knowledge for reconstruction and identification of these groups. Case Based Reasoning (CBR), especially modified to meet the needs of this work, has been used for tracing causality paths by similarity and making correction suggestions. Two case examples are presented to prove the functionality of the proposed methodology. Non-dimensional groups are used in engineering but can also be used in economic science. Through this analysis, we can calculate the scale of industrial processes from laboratory to pilot and then factory scale. Still through the study of non-dimensional groups, it is easy to calculate economies of scale embedded in the production process. Synergy savings and target economies cause economies of scale in a production process and reduce the cost of production per unit of output when production is increased. Non-dimensional groups can be a quantitative and measurable indicator for calculating and predicting economies of scale in an industrial unit. The same can happen in an economic unit providing services, that is, intangible products.

Keywords: dimensional analysis, knowledge acquisition, dimensionless groups, case based reasoning, data mining, Blake number, modified Reynolds number, adsorption, sedimentation, flocculation, filtration, scale up

Introduction

Some sizes are defined as the quotient of two identical sizes and so they are dimensionless or in other words they have a dimension that can be expressed by the number “1”. The associated SI unit for all dimensionless sizes, dimensions one, is number one, since the quotient of two SI units must be equal to one. The values of these sizes are simply expressed as numbers and the unit “1” is not next to them. Examples of such sizes are diffraction index, relative permeability, coefficient of friction, and so on.

In very few cases, however, separate names have been given to unit “1” to facilitate the separation of the

relevant sizes. This applies to the radian and steering. The radius and steering are recognized as special names for the associated SI units used to express the flat angle and solid angle values, respectively. In all these cases of counts the SI unit is considered to be the number one. The number one in these cases cannot be considered as a unit of production and therefore for these cases the number one can be considered as one additional basic SI unit.

Dimensional analysis is applied in those cases of flow of fluids that do not require a precise theoretical solution, or their mathematical solution is not possible.

Thus, in these cases the experimental study is followed where the dimensional analysis is applied in which the plurality of different sizes make up a limited number of non-dimensional groups for ease of reference.

Dimensional analysis was initially developed early in the last century (Rayleigh, 1900; 1915; Buckingham, 1914; Langahaar, 1951; Huntley, 1952; Palacios, 1956) by scientists and engineers for expressing the behavior of a physical system in term of the minimum number of independent variables and in a form that is unaffected by changes in the magnitude of the units of measurement. The first attempt to a similar approach in Economics was made by Allais (1943), who presented a systematic treatment of the theory of dimensions and its foundations. Later, some authors contributed to the diffusion of this scientific topic (e.g., see Jong, 1967) or used relevant techniques either for simply stressing the distinction between stock and flow variables (Boulding, 1966; Auckley, 1961) or for techno-economic analysis (Nussbaumer & Neuenschwander, 2000; Corre, Guillaum, & Mohand, 2002) or for model checking (Batzias & Sidiras, 2004). The physical and/or economic magnitudes are usually arranged in dimensionless groups (DGs), the number of which is $m = n - r$, where n is the number of dimensional variables/parameters/constants (VPCs) and r is the number of primary quantities used, like mass M , length L , time T , and temperature G . This rule is a general relation based on Linear Algebra and Group Theory and is mostly quoted as Buckingham's pi theorem.

In differential analysis, the fluid control volume, as above but in infinite dimensions where the principles of conservation of mass, momentum, and energy are also applied.

Thus, similarly with their application, the differential equations of their continuity arise, the solution of which, by using marginal initial conditions, provides precise values, or even distribution of fluid properties, such as e.g. speed, pressure, shear stress, etc. From these, it is even possible to calculate the maximum values of these sizes.

DGs may have physical meaning and in such a case we can search for similar groups through Case Based Reasoning (CBR) in order to properly describe quantitatively and solve similar problems, possibly occurring due to errors either in dimensions or in form or in content. CBR has been formalized for purposes of computer-aided processing as a four-step algorithmic procedure, which might be named 4R from the initial letter of the four verbs used as computer program commands in the corresponding steps: (I) Retrieve the cases considered to be relevant to solving a given target problem; (II) Re-use the solution (if it was successful) from the previous case to the target problem by making the necessary modifications to adapt the solution as needed to fit the new situation; (III) Revise by testing the solution of the new problem directly in the real world or indirectly under suitable conditions or reliable simulation; (IV) Retain by storing the solution as a new case in the computer memory, provided that the adaptation was a successful one.

Computer-aided solving by CBR the problems quoted above is a difficult task, especially when this approach uses unpublished evidence as its main Knowledge Base (KB); since the available information from the past may be not relevant/reliable to the required level for backing a successful

“implementation-by-analogy”, there is no guarantee that the necessary generalization (that ensures applicability) is correct. Nevertheless, inductive reasoning in case of scarce data/information for statistical relevance/reliability is usually based on incomplete evidence in practice. Moreover, there is always the possibility of developing CBR within a statistical framework and formalizing case-based inference as a specific type of probabilistic/possibilistic inference; therefore, it becomes feasible to make case-based estimates with a preset level of confidence.

Methodology

The methodological framework we have developed, in terms of a logical flow chart with 11 activity stages and seven decision nodes (interconnected as shown in Figure 1), to acquire/process/store/retrieve knowledge for reconstruction and identification of dimensionless groups by means of CBR, is presented below:

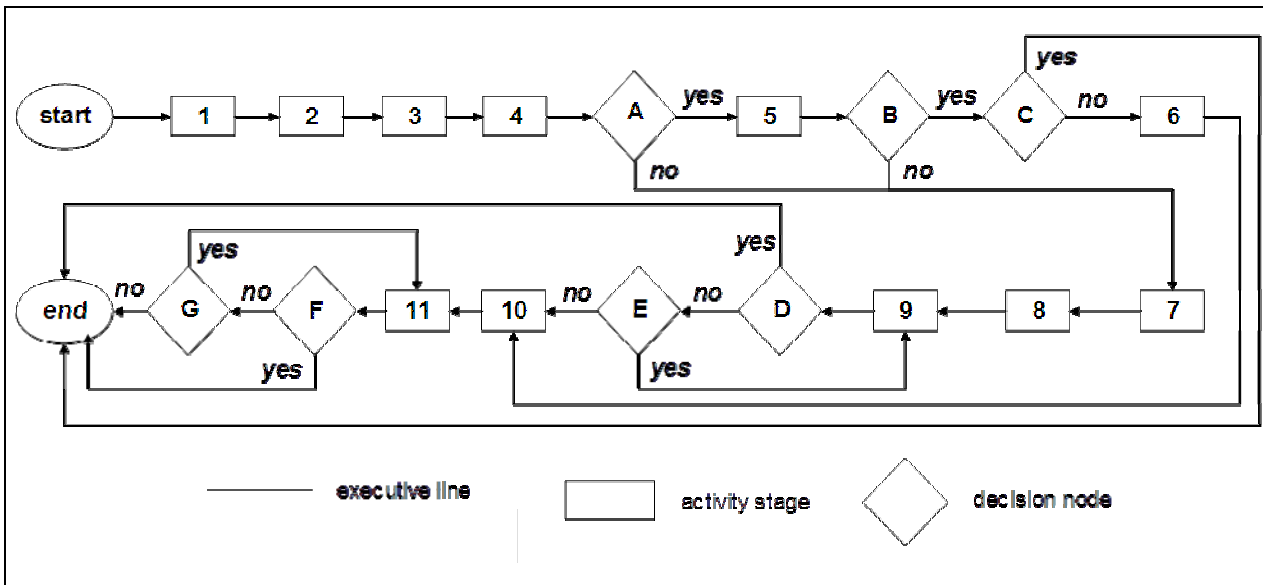

Figure 1. The logical flow chart developed for acquiring/processing/storing/retrieving knowledge for identification and correction of either dimensionally inconsistent VPCs or/and DGs in error.

- (1) Analysis of the DG in error or the dimensionally inconsistent VPC.
- (2) Checking of the definitions of the VPCs registered under widely known names in relevant KBs and, subsequently, in the corresponding original sources of technical literature.
- (3) Translation of these verbal or symbolic definitions into dimensional definitions in accordance with the dimensional system adopted from the start as most appropriate.
- (4) Replacement of the VPCs suspected to be in error with the new/checked ones and testing of the DG under consideration for dimensional homogeneity.
- (5) Checking for operability within a proper/successful paradigm extracted from a KB by means of data mining and knowledge acquisition techniques to be used in accordance with CBR.
- (6) Combinations of DGs to find out those which are more close to the DG under consideration.
- (7) Checking of these combinations for operability ab initio (i.e., without having necessarily a past successful paradigm).
- (8) Discrimination of relevant DGs and ranking of them in descending order of similarity degree as

regards the DG to be corrected.

(9) DA by replacing a priori the DG under correction with the most similar (but unexamined so far) DG within the set of DGs resulted as the solution of the dimensional matrix corresponding to the system of equations obtained according to Rayleigh's Method of Indices.

(10) Multicriteria ranking of combinations performed in stage 6, according to the order of decreasing degree of closeness to the DG under consideration.

(11) Checking of the first combination (among the ones not examined so far) for operability.

(12) Has dimensional homogeneity been restored?

(13) Is operability satisfactory?

(14) Is the new DG identified as the correction of the old one?

(15) Is this replacement successful?

(16) Is there another ranked DG with lower similarity degree?

(17) Is its operability satisfactory?

(18) Is there another ranked combination not examined?

Implementation

We have implemented successfully the methodology described above in a plethora of cases. Subsequently, we present two of them. The first refers to modified Reynolds or Blake Number, defined in Perry's Chemical Engineering Handbook (Perry & Green, 1997) as $B = V\rho/[\mu(1 - \varepsilon)S]$, where v : characteristic or average fluid velocity (m/s); ρ : fluid density (kg/m^3); μ : fluid viscosity (Pa s); ε : void fraction (m^3); S : particle area/volume ($1/\text{m}$); all magnitudes measured in SI units. By replacing the units with the corresponding dimensions, we obtain $B \in [\text{LT}^{-1}][\text{ML}^{-3}][\text{ML}^{-1}\text{T}^{-1}]^{-1}[\text{L}^3]^{-1}[\text{L}^2\text{L}^{-3}]^{-1}$ or $B \in [\text{L}^{-3}] \neq [1]$. Evidently, this is in error, since the result should be $B \in [1]$, i.e., dimensionless. Searching in external KBs by means of data mining and knowledge acquisition techniques incorporated within an Intelligent Agent (IA), according to Batzias and Marcoulaki (2002), we find the most recent reference source (Batzias, Kakos, & Nikolaou, 2005) with all common DGs, where $B = V\rho/[\mu(1 - \varepsilon)d]$, with $\varepsilon \in [1]$, while d is the characteristic particle diameter $d \in [\text{L}]$ as recognized by the computer aided DA procedure adopted herein and thoroughly described in Walker and Weatherley (2001). Working out as above, we obtain $B \in [\text{LT}^{-1}][\text{ML}^{-3}][\text{ML}^{-1}\text{T}^{-1}]^{-1}[\text{L}]^{-1}[\text{L}^2\text{L}^{-3}]^{-1}$ or $B \in [\text{L}^{-1}] \neq [1]$. By continuing the automatic searching, as shown in the flow chart of Figure 1, the computerized procedure identified finally the correct dimensions to be $\varepsilon \in [1]$ and $S \equiv d \in [\text{L}^{-1}]$, giving $B \in [1]$.

The second case example used for implementation is the Freundlich isotherm, which we have used recently (Costa & Marquez, 1998) to study by experimental simulation the dye adsorption in batch and fixed-bed systems:

$$Q = KC 1/n$$

where q = the amount of mass adsorbed per unit mass of the adsorbent [1]; C = the equilibrium concentration of the adsorbate, $[\text{ML}^{-3}]$; K = parameter related to adsorption capacity; n = parameter related to adsorption intensity, [1]. Most authors do not specify the dimensions of K , while several of the rest of them assign either $[\text{L}^3\text{M}^{-1}]$ or [1] (e.g., see Ng, Losso, Marshall, & Rao, 2002 or Bird, Stewart, & Lightfoot, 1960, respectively). Evidently, these dimensional assignments are in error, as the dimensional homogeneity of this isotherm requires

$K \in [M^{-1/n} L^3/n]$, although this assignment is meaningless, when its physical content is considered thoroughly. By referring mass M to dye in solution, dye adsorbent, adsorbent itself, we can split this primary dimension to M_s , M_d , M_t , respectively. Consequently, we can write the isotherm model in dimensional form as follows: $q = K_s K_d K_t C^{1/n}$, where $q \in [M_d M_t^{-1}]$, $C \in [M_s L^{-3}]$, $K_s \in [M_s^{-1} L^3]^{1/n}$, $K_d \in [M_d]$, $K_t \in [M_t^{-1}]$, which is meaningful as representing the real situation (facilitating also the scale up/down of the corresponding simulation procedures).

Discussion

Even in physical sciences and engineering/technology, this identification attempt becomes cumbersome and the computer program may fail to suggest a realistic solution without substantial human intervention. The probability to fail increases when the DG under investigation is incorporated into relations that change the original VPCs with others for sake of better fitting to system's specifications. For example, when the system is "fluid flow through porous media", B can be combined with the "resistance coefficient" DG expressed by the ratio $\psi = A^2 \epsilon^3 P / [Q^2 \rho (1 - \epsilon) l S]$ to give a relation of the general form $\psi = K/B^n$ in the procedure known as the Blake-Carman correlation, where A is the cross-sectional area of packing perpendicular to flow direction, P is the pressure difference, Q is the volumetric flow rate ($Q = VA$), l is the length of packing in the flow direction, K and n are parameters. In the low B -range (approximately, $B < 1$), $n = 1$, and by re-arranging the VPCs, we obtain the Kozeny-Carman equation $Q = A \epsilon^3 P / [K \mu (1 - \epsilon)^2 S^2 l]$, which is dimensionally homogenous, since $Q \in [L^3 T^{-1}]$ and $A \epsilon^3 P / [K \mu (1 - \epsilon)^2 S^2 l] \in [L^2][1][ML^{-1}T^{-2}][1][ML^{-1}T^{-1}][L^{-1}]^{-2}[L^{-1}]^{-1} = [L^3 T^{-1}]$.

In such a case, we cannot investigate any dimensional inhomogeneity in B since this DG does not appear per se in the final model while the investigation of any error propagation should be based on CBR where the similar cases to be retrieved should belong to a broader family of Kozeny-Carman equations. If, according to Batzias, Kakos, and Nikolaou (2005), S is replaced by d in B , then the Kozeny-Carman equation becomes $Q = A \epsilon^3 P / [K \mu (1 - \epsilon)^2 S d l]$. Consequently, the dimensional vector of the right-hand side of this equation becomes $[LT^{-1}]$ which is inconsistent with the left hand-side dimensional vector $[L^3 T^{-1}]$ denoting the correct dimensions of volumetric flow rate Q . The IA cannot identify the source of error unless provided with further information corresponding to ancestor relations. On the other hand, the inference engine searching within the KB may identify Q with the "superficial velocity" u_0 (i.e., the average linear velocity the fluid would have in the column if no packing were present) quoted as the dependent variable of Blake-Kozeny equation in the classic work (Batzias & Marcoulaki, 2002).

As a matter of fact, searching for the possible routes of error propagation and the corresponding implications is a "direct problem" while searching for the possible source of error through an identification procedure is the "inverse problem". In the case examined herein, searching for implications of error in Blake Number B is the direct problem while searching for the possible source of error in Kozeny-Carman equation is the inverse problem. It is also worthwhile noting that the same family of equations is frequently met under all pairwise combinations (i.e., Kozeny-Carman, Blake-Carman, Blake-Kozeny) leading to additional difficulties faced by the IA searching in external KBs using the keywords interface suggested in Batzias and Marcoulaki (2002).

Conclusion

In conclusion, we have indicated the functionality of the methodological framework presented herein by analyzing two simple cases, one for DG and another for VPC. If the DGs or VPCs in error have been incorporated/combined into/with other expressions, traceability decreases and human intervention, at least for changing the searching pattern through CBR, increases the effectiveness of computer aided performance while facilitates the KB's enrichment/restructuring.

In the past, economic activity was considered to be limited by natural resources, labor, and capital. This view, however, ignores the value of technology (which often means automation, speeding up processes, and lower operating costs) and innovation (which means new products, services, processes, and markets, but also expansion of markets, diversification of markets, niche markets, and increased revenue from various functions), especially those that produce intellectual property. A given economy is the result of a set of processes including culture, values, education, technological development, history, social organization, political structure, legal systems, geography, natural resources, and ecology of the environment, as main factors. These factors give context, content, and a set of conditions and parameters on the basis of which a given economy operates. An economy consists of the economic system of a country or other unit of human society. It includes labor, capital, natural resources, production, trade, distribution and consumption of goods and services in the area where human society is active. These factors give context, content, and determine the conditions and parameters with which the economy operates.

Economies of scale are a term of finance, referring to the reduction of costs that an enterprise achieves by increasing the quantity of the product produced and characterizing the production of any product. Although at first sight it seems strange, economies of scale are observed in the production of most products. This also leads to a clear trend of business growth and concentration of production on a few and very large players.

Non-dimensional groups are used in engineering but can also be used in economic science. Through this analysis, we can calculate the scale of industrial processes from laboratory to pilot and then factory scale. Still through the study of non-dimensional groups, it is easy to calculate economies of scale embedded in the production process. Synergy savings and target economies cause economies of scale in a production process and reduce the cost of production per unit of output when production is increased. Non-dimensional groups can be a quantitative and measurable indicator for calculating and predicting economies of scale in an industrial unit. The same can happen in an economic unit providing services, that is, intangible products.

References

- Allais, M. (1943). *Traite d' economie pure*. Vol. I, Les Donnees generals de l' economie pure, Paris and vol. IV, Annexes.
- Auckley, G. (1961). *Macroeconomic theory*. New York.
- Batzias, F. A., & Sidiras, D. K. (2004). Dye adsorption by calcium chloride treated beech sawdust in batch and fixed-bed systems. *Journal of Hazardous Materials*, 114, 167-174.
- Batzias, F. A., & Marcoulaki, E. C. (2002). Restructuring the keywords interface to enhance CAPE knowledge acquisition via an intelligent agent. *Computer Aided Chemical Engineering*, 10, 829-834.
- Bird, R. B., Stewart, W. E., & Lightfoot, E. N. (1960). *Transport phenomena* (pp. 196-200). New York: Wiley.
- Boulding, K. E. (1966). *Economic analysis* (4th ed., Vol. II). New York.
- Costa, C., & Marquez, M. C. (1998). Kinetics of the PACT process. *Water Research*, 32, 107-114.
- Huntley, H. E. (1952). *Dimensional analysis*. London, Mac Donald.
- Jong, F. J. (1967). *Dimensional analysis for economists*. Amsterdam: North Holland Publ. Co.
- Langahaar, H. E. (1951). *Dimensional analysis*. London.

- Ng, C., Losso, J. N., Marshall, W. E., & Rao, R. M. (2002). Physical and chemical properties of selected agricultural byproduct-based activated carbons and their ability to adsorb geosmin. *Bioresource Technology*, 84(2), 177-185.
- Nussbaumer, T., & Neuenschwander, P. (2000). A new method for an economic assessment of heat and power plants using dimensionless numbers. *Biomass Bioenerg*, 18, 181-188.
- Palacios, J. (1956). *Dimensional analysis*. London: Mac Millan.
- Perry, R., & Green, D. (1997). *Perry's chemical engineers' handbook* (7th ed., pp. 648-650). McGraw-Hill.
- Walker, G. M., & Weatherley, L. R. (2001). Adsorption of dyes from aqueous solution—The effect of adsorbent pore size distribution and dye aggregation. *Chemical Engineering Journal*, 83, 201-206.



The Impact of On-the-job Training on Job Mobility of Migrant Workers in China

Jiang Jin-qi, Wang Zhen-hua

Shenyang Agricultural University, Shenyang, China

Chen Jing-wen

Liaoning Academy of Agricultural Sciences, Shenyang, China

The effect of on-the-job training on job mobility is an important topic in labor economics. Based on a sample survey data of migrant workers in Liaoning Province China, this paper has statistically described job mobility of migrant workers and then used a multinomial Logistic model to analyze the effect of on-the-job training on job mobility. We found, firstly, migrant workers have high-level job mobility; secondly, inter-firm/city occupational mobility is the major type of migrant workers' mobility, and then followed by the inter-firm mobility and inter-regional mobility that without occupation change; thirdly, on-the-job training has a significant impending effect on interregional mobility and occupational mobility, while has insignificant effect on inter-firm mobility.

Keywords: on-the-job training, job mobility, migrant workers, multinomial logistics model

Introduction

The long-term stability of employment is very important for migrant workers' permanently civilization. But the real facts are that they rarely have long-term contracts with employee, job turnover frequently (Huang, 2010) and the employment duration of new generation migrant workers are becoming shorter (Kou & Liu, 2013). And these mean migrant workers' employments are unstable, facing with high uncertainty. Therefore, we need to analyze their job mobility in-depth, and find the key to reduce their job turnover.

In labor economics theory, on-the-job training is the main investment of human capital after people have graduated from school and enter the labor market. Because it can increase the stock of human capital, it plays an important role in job mobility. Becker (1964), in a perfect competition framework, made the first theoretical

Acknowledgments: The authors are grateful for financial support from the Social Science Foundation of Liaoning Province (L16BGL038), Program for Liaoning Excellent Talents in University (WJQ2015026), the Youth Project of the Philosophy and Social Science Research, Ministry of Education of China (13YJC790057), and the National Natural Science Foundation of China (71303161, 71503173). And also thanks to YANG Xiaoli, ZHOU Mi, TAN Xiaoting, ZHANG Jinmei, LIU Qiang, and WANG Yu for helpful comments.

Jiang Jin-qi, Ph.D., associate professor, Department of Agricultural and Resource Economics, College of Economics and Management, Shenyang Agricultural University, Shenyang, China.

Wang Zhen-hua, assistant professor, Department of Agricultural and Resource Economics, College of Economics and Management, Shenyang Agricultural University, Shenyang, China.

Chen Jing-wen, M.A., Department of Accounting, Liaoning Academy of Agricultural Sciences, Shenyang, China.

Correspondence concerning this article should be addressed to Wang Zhen-hua, College of Economics and Management, No.120 Dongling Road, Shenyang, China.

discussion of the relationship between on-the-job training and mobility. In this research, he classified on-the-job training into two types: general training and specific training. Due to the fact that the human capital from general training can rise the labor productivity equally in many firms and the human capital from specific training can only have value in the training firm or in a specific occupation, he inferred that specific training could impede the mobility, while general training has not impact on mobility (Becker, 1964; Mincer, 1993; Zweimuller & Winter-Ebmer, 2003; Asplund, 2005). Since then, scholars have further discussed the theoretical problems as training cost sharing (Hashimoto, 1981), and the mechanisms why firms provide general training under imperfect competition (Katz & Ziderman, 1990; Stevens, 1994; Acemoglu & Pischke, 1998), and concluded that general training has multidimensional effect on labor mobility. It may be an increasing effect, an inhibiting effect, and even may be no effect. In empirical, the studies with data from EU and US have provided many evidences of the impact on-the-job training on mobility. In summary, these evidences have solidly confirmed the impending effect of specific training (Mincer & Jovanovic, 1981; Weiss, 1984; Mincer 1993; Light & Ureta, 1992; Farber, 1994; Parent, 1999), and the impact of general training varies widely (Lynch, 1991; Korpi & Mertens, 2003).

For Chinese rural migrant workers, under the situation that they are homogeneous in formal education and all are lower education level (Chen, Jiang, & Zhang, 2015), the attainment of on-the-training in their urban employment would widen the human capital gap among them, which therefore would have differentiated impact on their job mobility. However, the effect of on-the-training on migrant workers mobility is unclear, only little few literatures have discussed it. Having concluded these studies, we found that they only analyzed the impact of on-the-job training on the overall incidence of job turnover (Xie, 2009; Chen et al., 2011; Zhang & Shen, 2013; Jiang, Zhang, Qi, & Zhou, 2016; Jiang & Chen, 2016). But, there are types of job mobility, so we need to further explore the effect of training on each type of mobility and find the differences of its effects. In this paper, we classify job mobility with spatial and occupation dimensions together and then use a multinomial logistic model to study the impacts of on-the-job training on different types of mobility.

The remainder of the paper is structured as follows. The next section provides a brief description of the data, the multinomial logistic model and its variables. And a detailed illustration of the empirical results follows. Finally, some conclusions and comments are provided.

Data, Model, and Variables

The Classification of Job Mobility

Job mobility manifests itself as job change or job turnover in the labor market. From the theory of labor economics, job mobility has been classified into three kinds by jobs' spatial and occupational characteristics. The first that workers change their employee, while their occupation and working area unchanged, is an inter-firm mobility. The second category that workers change their working area and employee while their occupation unchanged, is an inter-regional mobility. The last category that workers either change occupation in their working unit, or change occupation from one employee/area to another employee/area, is inter-occupational mobility (Borsch-Supan, 1987; McConnell, Brue, & Macpherson, 2003).

Following these classifications of job change, we classify the job mobility of migrant workers by the change of employee, area and occupation from their first job to present job into three kinds: inter-firm mobility, inter-regional mobility, and inter-occupational mobility.

Data

The data used in this paper come from a sampling survey of migrant workers' employment in six cities in Liaoning province of China. The survey was completed in 2014, and conducted by Sannong Institute, Shenyang Agricultural University. The data are obtained by stratified sampling. Specifically, we first, according to the geographic location, level of economic development, and city size, selected one large city (Shenyang), two medium cities (Fuxin and Jinzhou) and three small cities (Taian, Changtu, and Kaiyuan) as the survey area, and then, according to the industrial distribution of migrant workers in the monitoring survey conducted by the National Bureau of Statistics of China and regional distribution of migrant workers in Liaoning Province, we determined the sample size in each industry and city, and finally obtained a population of 1,242 observations.

Prior to analyze, we do some data cleanings. Firstly, we drop these observers that their first jobs are self-employment. Secondly, we drop these observers that they begin their urban employment in 2014. And finally, we delete the observers that they have missing value in their first job survey data. After data cleaning, there are 751 observations in the following empirical analysis.

Model and Variables

As previously mentioned, this paper focuses on the impact of on-the-job training on different types of labor mobility of migrant workers. According to value characteristics of the variable of job mobility, we establish equation (1) as the regression model and use a multinomial logistic method to estimate:

$$\begin{aligned} & \text{prob}(\text{jmobtype} = j | \text{cztrain}, X, \varepsilon_2) \\ &= \frac{\exp(\alpha_j + \beta_j \cdot \text{cztrain} + \sum_{ji} \gamma_{ji} X_{ji} + \varepsilon_{j2})}{1 + \exp(\alpha_j + \beta_j \cdot \text{cztrain} + \sum_{ji} \gamma_{ji} X_{ji} + \varepsilon_{j2})} \quad (j = 0, 1, 2, 3) \end{aligned} \quad (1)$$

In equation (1), the dependent variable *jmobtype* is the job mobility, which includes four values: non-mobility, inter-firm mobility, inter-regional mobility, and inter-occupational mobility. The explainable variable *cztrain* is on-the-job training. Judging from the existing research, there may be simultaneous causal relationship between on-the-job training and job mobility¹ (Mincer, 1989; Wolter & Aarau, 2001; Weng, 2006), and it will lead to estimation bias. To eliminate this bias, we use the training in their first job to indicate on-the-job training. Furthermore, in the previous studies, scholars usually classified the training into general training and specific training². However, in this article, such distinction of training is seldom to be achieved, because there are very few workers who have general training. And there are three groups of control variables. The first group is the characteristics of workers' first job, such as the occupation, working duration and its square term, wage, and city size. The second group is the demographic characteristics of workers, such as intergenerational attribution and gender. The third group is human capital other than training, such as education level, skills, and off-farm working experience before migration. The definition and description of variables are listed in Table 1.

¹ If workers change jobs frequently in their previous working career, once such information is known to the firms, there is a high probability that firms are unable to offer training for them, because these people have a very high risk of quit after training, and the training cost which firm spends may be unrecoverable. In addition, those people who often change job will be marked with the label of disloyalty, and therefore firms are reluctant to provide training to them. Due to the above two reasons, job mobility is an important explanatory variable for on-the-job training attainment.

² In general, there are two ways to distinguish the general training and specific training in empirical studies. First, scholars distinguish training by the supplier of training. If training is provided by workers, government, or other commercial organizations, it should be classified into general training. If training provided by the company, it should be identified as specific training. The second is to differentiate according to the sharing of training costs. If the trained workers share a very low proportion of cost, the training is defined as specific training; and it should be viewed as general training when trained workers share a high percentage of the total cost.

Table 1

Variables Definition and Description

Variables	Definition and value code	Mean	S.d
Jmobtype	Job mobility types: 0 non mobility, 1 inter-firm mobility, 2 inter-regional mobility, 3 inter-occupational mobility	1.683	1.162
Cztrain	Whether has on-the-job training or not: 0 no, 1 yes	0.406	0.491
Gender	Gender types: 1 male, 2 female	1.520	0.500
Newge	The generational attribution: 0 older generation, 1 new generation	0.507	0.500
Occupa	The occupation classification of first job: 1 waiters/clerks, 2 low-skill workers, 3 high-skill workers, 4 managers	1.934	0.843
Wdurat	The duration of first job	4.622	5.716
Wdurat ²	The square term of first job's duration	53.990	137.798
Wage	The hourly wage of first job	6.124	5.508
City	The city size of first job: 1 small city, 2 medium city, 3 large city	2.164	0.804
Eduyear	Years of education	8.905	2.144
Skill	Whether has skills before migration: 1 yes, 2 no	1.770	0.421
Ofarm	Whether has off-farm employment before migration: 1 yes, 2 no	1.772	0.420

The Empirical Results

The Status of Job Mobility

Table 2 is the statistical description of job mobility of migrant workers. From the results in Table 2, we find that job mobility of migrant workers is very common, and 78.47% of the overall workers' present job is different their first job. Among the workers whose job has changed, the proportion of inter-occupational mobility is largest, followed by the inter-firm mobility, and the inter-regional mobility is the least. The percentage of these three kinds of workers in the overall population are 35.02%, 23.64%, and 19.8% respectively.

As for group workers with gender and age for a more detail investigation, we found that male migrant workers have higher mobility than female. Among those female and male workers have job turnover, inter-occupational mobility accounts for the highest proportion of 30.24% and 40.21% in both group, and larger percent in male than female; and less than inter-occupational mobility is inter-firm mobility in female and inter-regional mobility in male; the last is inter-regional mobility in female and inter-firm mobility in male. The percentage of inter-firm mobility and inter-regional mobility in female group are 27.14% and 17.38%, and 19.85% and 22.42% in male group. From the results in two age groups, we consider that job turnover is more obvious in new generation group, nearly 85% of this group workers have changed their job, and this percentage is higher than the old generation 12 points. Furthermore, in each age group, inter-occupational mobility is the largest part in job changing workers. Especially for new generation group, this percent is very large, and has reached 43.66%. For inter-firm mobility and inter-regional mobility, the former has larger percent than the later in both age groups, and they are high in the old generation group.

Table 3 provides a brief description of the relationship between on-the-job training and job mobility through the comparison of training and non-training groups. We find migrant workers who have received training in their first job have an obvious decline in mobility. The mobility incidence has decreased from 82.29% in the non-training group to 72.87% in the training group, about 10 percent decreasing. Moreover, for three kinds of mobility, the proportion inter-occupational mobility in the training group is indifference from the

non-training group, all about 35% in these two groups. The proportion of inter-firm mobility in training group is slightly lower than the non-training group. There is a 2.3 percent distance between these two groups. Migrant workers in the training group have significant less inter-regional mobility than non-training workers, up to 7.7 points decline in percentage. And these mean the inhibition effect of on-the-job training on mobility is mainly from its effect on inter-regional mobility.

Table 2

Job Mobility of Migrant Workers (%)

Group	Non mobility	Inter-firm mobility	Inter-regional mobility	Inter-occupational mobility
Overall	21.53	23.64	19.8	35.02
Female	25.24	27.14	17.38	30.24
Male	17.53	19.85	22.42	40.21
Old generation	27.39	25.38	21.11	26.13
New generation	15.85	21.95	18.54	43.66

Table 3

On-the-job Training and Job Mobility (%)

Employment mobility type	Non-training	Training
Non mobility	17.71	27.13
Inter-firm mobility	24.58	22.26
Inter-regional mobility	22.92	15.24
Inter-occupational mobility	34.79	35.37

The Effects of On-the-job Training on Mobility

In this section, we use a multinomial logistic method to estimate the migrant workers' job mobility model in equation (1) for identifying the impact of on-the-job training. The regression results are shown in Table 4. The value of Wald χ^2 test is 200.58, which passes the statistical test at the significance level of 1%. This shows that the independent variables in equation (1) as a whole have strong explanation on migrant workers' job mobility.

Then we give a detailed illustration of the impact of on-the-job training. First, for the inter-firm mobility, on-the-job training, even it has a negative coefficient, failed to pass the variable significance test. Therefore, we believe that training is helpless to impede inter-firm mobility. For the inter-regional mobility and inter-occupational mobility, on-the-job training not only has a negative coefficient in these types of mobility, but also passes the significance tests at 5% level. And this means training has significantly inhibited effect on inter-regional mobility and inter-occupational mobility of migrant workers. Having calculated the marginal effect of training, we found that the probability of inter-regional mobility and inter-occupational mobility would drop by 4.69% and 6.57% respectively, for those workers who had been trained in their first job. From the results in three kinds of job turnover, we consider that, from the view of firms, providing training as an investment of human capital to migrant workers does not meet their economic interests, because the return of training has strong spillover effect in an industry, and training supplying firm cannot gain the total benefits of training. But from the standpoint of local governments, encouraging firm to train migrant workers is very helpful to enhance the overall stock of human capital in local area, and it would improve the local labor productivity.

Table 4

The Multinomial Logistic Outcome

Variables	Value	Inter-firm mobility	Inter-regional mobility	Inter-occupational mobility
Cztrain	Have	-0.347 (0.267)	-0.706** (0.286)	-0.677** (0.277)
Occupa	Low-skill worker	0.017 (0.301)	-0.506 (0.313)	-0.039 (0.302)
	High-skill worker	-0.125 (0.439)	-0.740 (0.472)	0.179 (0.418)
	Manager	-0.215 (1.120)	0.205 (1.103)	0.335 (0.888)
Wdurat		-0.424*** (0.065)	-0.316*** (0.066)	-0.386*** (0.064)
Wdurat ²		0.010*** (0.003)	0.009*** (0.003)	0.010*** (0.003)
Wage		-0.185*** (0.044)	-0.280*** (0.068)	-0.184*** (0.043)
Newge	New generation	-0.117 (0.318)	0.048 (0.353)	0.699** (0.305)
Gender	Female	-1.115*** (0.338)	-1.712*** (0.348)	-1.462*** (0.340)
Eduyear		-0.019 (0.061)	0.032 (0.064)	-0.036 (0.061)
Skill	No	-0.346 (0.386)	-0.632* (0.381)	-0.747** (0.357)
Ofarm	No	-0.831** (0.373)	-0.720* (0.392)	-1.109*** (0.359)
City	Medium city	0.354 (0.345)	1.806*** (0.369)	1.124*** (0.342)
	Large city	0.262 (0.322)	1.243*** (0.372)	1.088*** (0.320)
Constant		4.850*** (0.867)	4.144*** (0.940)	4.733*** (0.865)
Wald Chi ²		200.58***	Pseudo R2	0.192

Notes. *, **, and *** represent the significance level of 10%, 5%, and 1%; The value in bracket () is standard error; Non mobility group is the references in the regression.

Except on-the-job training, the results of control variables show that the duration of first job and its square term, wage of first job, gender, and off-farm working experience before migration are the common factors that they all pass the significance explanation in three kinds of mobility. For their impacts, we found that the probability of mobility would decline and then turn to increase promptly along the duration extending. The wage of first job is negative related with migrant workers' job turnover, and this means that those workers with high wage in their first job are less likely to change job. Female migrant workers have less job change than male migrants. And the workers without off-farm job experiences before migration have lower probability to turnover.

In addition, the variables of occupation and city size of first job have substantial impact on inter-regional mobility of migrants, while the variables of skills and city size of first job have strong influences on

inter-occupational mobility. Specifically, these workers who engaged in low-skilled jobs and high-skilled jobs have low-level mobility incidence than those who engaged in waiters/clerks, but workers who engaged in management workers are indifference from those engaged in waiter/clerk jobs. Workers that have skill before migration are more likely to change their occupation. And those workers who have their first job in medium city and large city have a higher probability of inter-regional and inter-occupational mobility than those who worked in small city.

Conclusions and Comments

Based on the sampling survey data in Liaoning Province, this paper has statistical described job mobility of migrant workers and then used a multinomial logistic model to analyze the effect of on-the-job training on job mobility of migrant workers. The main findings are: (1) High job mobility is an important feature of migrant workers' urban employment. In this survey, 78.47% of the total respondents have changed their jobs. (2) Inter-occupational mobility is the most common type in job mobility, and then followed by the inter-firm and inter-regional mobility. As the percentage of mobility workers in the sample, 35.02% of the migrant workers have inter-occupational mobility, 23.64% of these workers are inter-firm mobility, and 19.8% of these workers are inter-regional mobility. (3) Male migrant workers and new generation migrant workers have more mobility than female and old generation. And the results of mobility type suggest that, inter-occupational mobility accounts for the highest proportion in all subgroups, and there are high-level inter-firm mobility and low-level inter-regional mobility in female and old-generation subgroup, low-level inter-firm mobility and high-level inter-regional mobility in male and new generation subgroup. (4) On-the-job training has a significant inhibitory effect on inter-regional mobility and inter-occupational mobility of migrants workers, but cannot contribute to reduce job turnover from one fire to another counterparts. (5) The duration of first job and its square term, wage of first job, gender and off-farm working experience before migration have significant impacts on three kinds of job mobility of migrants, occupation and city size of first job have substantial impact on inter-regional mobility, and the variables of skills and city size of first job have strong influences on inter-occupational mobility.

The modern human capital theory indicated that, people can increase their human capital by experience and knowledge accumulation with "learning by doing" and training during a long-term stable job. The change of job may mean the process of human capital accumulation and its effect on production has been broken off. However, there are inconsistent effects of different kinds of job mobility on this human capital accumulation. In general, inter-firm and inter-regional job mobility within a occupation level, although can interrupt this human capital accumulation, due to the human capital from the last job could be continued to have same effects on the next job, so these mobility have very small impact on people's human capital. For inter-occupational mobility, the human capital (especially for that firm-specific or occupation-specific capital) from last job cannot be used in the new job completely, and this means a sinking of human capital. Therefore, inter-occupational mobility has more significant negative effects on human capital than inter-firm and inter-regional mobility. For migrant workers who have few formal educations in school, inter-occupational mobility will be harmful to human capital accumulation, which in turn have more negative effect on employment improvement and wage increasing. From our findings in this paper, inter-occupational mobility is precisely the main form of migrant workers' job mobility. In the new generation and male subgroup, this is even more serious. Therefore, before to resolve the problem of job mobility of migrant workers, we should first understand the real facts that migrant

workers often change their job from one occupation to another and inter-occupational mobility has serious negative effects. If we hope to stabilize employment to promote the civilization of migrant workers and thus accelerate the urbanization in China, we should find effective solution to decrease the inter-occupational mobility of migrants at first.

From the multinomial logistic regression results, we consider that on-the-job training can be used as an effective policy tool to reduce the inter-occupational job changing. At the same time, the result that on-the-job training is ineffective on inter-firm mobility means that there is a significant spillover effect of training providing by the employment in local labor market. Therefore, policy maker should pay full attention to this point. According to the real facts of migrant workers, we suggest building a training supply mechanism that firms provide a list of training needs, then central and local governments bidding and purchase training, and last firms monitor and evaluate the ex-post effects of training.

References

- Asplund, R. (2005). The provision and effects of company training: A brief review of the literature. *Nordic Journal of Political Economy*, 31, 47-73.
- Acemoglu, D., & Pischke, J. S. (1998). Why do firms training? Theory and evidence. *Quarterly Journal of Economics*, 113(1), 79-119.
- Becker, G. S. (1964). *Human capital: A theoretical and empirical analysis, with special reference to education*. Chicago: University of Chicago Press.
- Borsch-Supan, A. (1987). The role of education: Mobility increasing or mobility impeding? NBER Working Paper No. 2329.
- Chen, Z. J., Yi, Y., Deng, Y., et al. (2011). The employment stability of new generation migrant workers and its factors. *Journal of Jiangxi Agricultural University*, 10(1), 11-17.
- Chen, J. W., Jiang, J., & Zhang, G. S. (2015). Social network, job-seeking methods and wage determination of new generation migrant workers. *South China Population*, 30(4), 69-80.
- Farber, H. S. (1994). The analysis of interfirm worker mobility. *Journal of Labor Economics*, 12(2), 554-593.
- Hashimoto, M. (1981). Firm-specific human capital as a shared investment. *American Economic Review*, 71(3), 475-482.
- Huang, Q. (2009). Migrant workers' employment stability and its wage effect. *Population Research*, (9), 55-64.
- Jiang, J. Q., & Chen, J. W. (2016). The effect of job-related training on labour mobility of rural migrant workers: An empirical analysis on sample data of Liaoning province. *Statistics & Information Forum*, 31(9), 86-91.
- Jiang, J., Zhang, G., Qi, D., & Zhou, M. (2016). Can on-the-job training stabilizing employment among rural migrant workers? *China Agricultural Economic Review*, 8(3), 498-515.
- Katz, E., & Ziderman, A. (1990). Investment in general training: The role of information and labor mobility. *Economic Journal*, 100, 1147-1158.
- Korpi, T., & Mertens, A. (2003). Training systems and labor mobility: A comparison between Germany and Sweden. *Scandinavian Journal of Economics*, 105(4), 597-617.
- Kou, E., & Liu, B. (2013). The stable employment and wage gap of rural migrants in urbanization. *Journal of Quantitative & Technical Economics*, 30(7), 3-19.
- Light, A., & Ureta, M. (1992). Panel estimates of male and female job turnover behavior. *Journal of Labor Economics*, 10(2), 156-181.
- Lynch, L. M. (1991). The role of off-the-job vs. on-the-job training for the mobility of women workers. *American Economic Review*, 81(2), 151-156.
- McConnell, C. R., Brue, S. L., & Macpherson, D. A. (2006). *Contemporary labor economics* (7th ed.). Iwrin/McGraw-Hill Company.
- Meng, F., & Wu, J. (2013). The transition of employment stability in China and the influencing factors: an analysis base on CGSS Data. *Population and Economy*, (5), 81-90.
- Mincer, J. (1993). *Job training, wage growth, and labor turnover*. Studies in Human Capital, E. Elger Publishing.
- Mincer, J., & Jovanovic, B. (1981). *Labor mobility and wages*. Studies in labor market. Chicago: University of Chicago Press.
- Parent, D. (1999). Wages and mobility: The impact of employer-provided training. *Journal of Labor Economics*, 17(2), 298-317.

- Stevens, M. (1994). A theoretical model of on-the-job training with imperfect competition. *Oxford Economic Papers*, 46, 537-562.
- Weiss, A. (1984). Determinants of quit behavior. *Journal of Labor Economics*, 2(3), 371-387.
- Weng, J. (2006). Research on human capital investment based on employment relationship stability. Doctoral dissertation of Zhejiang University, Hangzhou.
- Wolter, S. C., & Aarau, B. (2001). Training incidence and job-mobility in Switzerland. ECER 2001 Conference, Network 2.
- Xie, Y. (2009). Analyze of the factors of migrant workers' job quality: A case of Nanjing City. *Finance and Trade Research*, 112(5), 38-42.
- Zhang, Y. H., & Shen, Q. Q. (2013). The stability of the employment of peasant-workers and its influencing factors. *Management World*, 3, 176-177.
- Zweimüller, J., & Winter-Ebmer, R. (2003). On-the-job training, job search and job mobility. *Swiss Journal of Economics and Statistics*, 139(4), 563-576.



Analysis of the Relationship Between GDP and FDI on the Economic Growth of Laos

Thanet Wattanakul

Khon Kaen University, Khon Kaen, Thailand

In the current globalization stream, the foreign investment is an important role not only for developed country but at all especially the least developing country as Laos. This study aims to examine the relationship between the gross domestic product (GDP) and foreign direct investment (FDI) on economic growth of Laos by using data from 1985 to 2014. The long run relationship was analyzed by Johansen co-integration test and estimated the speed of adjustment by Vector Error Correction approach. Estimated results indicated that there was long run relationship running from FDI to GDP and the relation would return to the equilibrium in about 19 when it occurred. This study suggests that policy maker should improve the other factor for motivated FDI and accelerate Lao economy.

Keywords: GDP, FDI, Laos, co-integration, VECM

Introduction

Globalization is currently becoming an important role in the global economy. All countries are connected by invisible network in form of social network to increase convenient of connecting people in each region. The effects of Asian crisis in 1997, Hamburger crisis in 2008, European debt crisis in 2009, European Union leaving of England in 2016 have contributed to the fragile and instable of global economy that has to be cooperatively insulated.

One of the essential and necessary networks to connect economy of each state is investment particularly for foreign direct investment (FDI). Investment can be regarded as the instrument and policy to expand and distribute product as well as service via using massive input for manufacturing industries. Nevertheless, in the long run, the resources will not be enough and cost of utilization will be higher. As a result, the investment in other countries in terms of FDI may solve these problems by seeking lower input cost and optimal location for production or distribute product in other locations. Therefore, the sensitivity of economic changing environment and competition in each country will affect the linkage country of these countries not only home countries but also host countries.

FDI is attracted by many factors of host countries such as location, suitable economic policies and transparency competition environment as well as other related factors. Dunning (2001) proposed three advantages which motivate foreign investment such as location advantage, ownership advantage, and

Thanet Wattanakul, Ph.D. of Applied Economics, assistant professor, Department of Economics, Faculty of Integrated Social Sciences, Nong Khai Campus, Khon Kaen University, Khon Kaen, Thailand; consultant of the Indo-China International Trade and Economy Research Sector.

Correspondence concerning this article should be addressed to Thanet Wattanakul, Faculty of Integrated Social Sciences, Nong Khai Campus, Khon Kaen University, Khon Kaen 43000, Thailand.

internationalization advantage in eclectic (LOI) paradigm of international production. Meanwhile, host labor countries will receive rent and they can buy their resource to increase investment. The win-win relation between host country and foreign investor can be emerged. This theory also supports the new opinion of Selma KURTISHI-KASTRATI in 2013 which explains the benefits of FDI for host country's economy. In addition, the costs of FDI to host country's economy such as adverse effects on employment and the net number of new jobs effected via FDI may not be great as initially claimed by an MNE (Kurtishi-Kastrati, 2013). This effect can be considered as adverse effects on competition. It may be monopolized market if the international organization has a lower average cost from the advantage and adverse effects on balance of payment because the outflow from profit of international organization returns to home countries.

There is insufficient of domestic investment in most developing countries to accelerate their economy growth because of both many low income and saving including capital accumulation. As a consequence, the need of FDI is of important concern. Borensztein, De Gregorio, and Lee (1988) found that the foreign investment effect is essential factor to drive technology development and support economic growth in developing countries. Moreover, FDI is more important than local investment in developing country. Carkovic and Levine (2002) found the effect of human resource development and foreign investment on economic growth. High performance of human resource counties and foreign direct investment play more important roles than other lower countries.

There is relationship between cost of home countries and benefits of host countries which are different from different countries. However, there is possibly negative relationship between FDI and GDP which could happen especially in developing countries. Therefore, this relationship should be proved by using empirical study particularly for the developing countries in Greater Mekong Sub-region such as Laos and by using appropriate econometric model estimation. The empirical results can be used as related policy implementations guideline for both Laos and Thailand's public and private organizations.

This study aims to investigate the relationship between FDI and GDP of Laos. It is divided into four sections: Introduction in section 1; the next section is methodology; results and discussion are proposed in section 3; the last section is conclusion; and policy is in section 4.

Methodology

This study examines the relationship between FDI and GDP of Laos by using time series data from 1985 to 2014. The data of FDI stock of Laos were collected from UNCTAD while GDP at constant price in 2005 was collected form World Bank. All time series data were tested stationary potential by Augment-Dickey Fuller test (ADF-test) and Phillip-Perron test (PP-test). In addition, the time series data were tested co-integration by using the Johansen co-integration approach to investigate long-run relationship. Short-run relationship and adjustment to equilibrium were examined by using Vector Error Correction Mechanism (VECM).

Stationary Test

Almost time series data have stochastic trend or unit root processes (Nelson & Kang, 1981). The results from ordinary least square (OLS) estimation can be spurious that is considerably high R^2 but low Durbin-Watson statistic. This problem is called spurious regression. Besides, the variables have stochastic trend are call non-stationary variables. Therefore, the first step of estimation time series by using OLS estimator has to detect the stationary potential and use method calls stationary test or unit root test.

This study investigated stationary potential by using ADF-test and PP-test which traditionally process for unit root testing. Estimated model can be present as follows:

$$\Delta X_t = \alpha X_{t-1} + \sum_{i=1}^p \omega_i \Delta X_{t-1} + \varepsilon_t \quad (1)$$

$$\Delta X_t = \delta + \alpha X_{t-1} + \sum_{i=1}^p \omega_i \Delta X_{t-1} + \varepsilon_t \quad (2)$$

$$\Delta X_t = \delta + \gamma\theta + \alpha X_{t-1} + \sum_{i=1}^p \omega_i \Delta X_{t-1} + \varepsilon_t \quad (3)$$

where X_t is explained variable, δ is constant, $\gamma\theta$ is time trend, ε_t is error term, $\sum_{i=1}^p \omega_i \Delta X_{t-1}$ is autoregressive process, and α is coefficient of X_t in the last previous. Non intercept and trending variables would be tested by equation (1), intercept variables would be tested by equation (2), and intercept and trending variable would be tested by equation (3). Coefficient (α) was transformed into ADF-t statistic as follows:

$$ADF = \frac{\hat{\alpha}}{SE(\hat{\alpha})} \quad (4)$$

ADF-t statistic has to be compared with McKinnon critical value for concluding stationary potential. Stationary potential can be accepted when ADF-t statistic was less than McKinnon critical value but the statistic was more than the critical value, the variable was non-stationary.

Although non-stationary potential was detected at level of integrated or I (0), the variable may be stationary at higher order of integrated (I (1) or I (2)). They probably have long-run relationship. Thus, they should be tested again at the higher order of integrated.

Co-integration

Time series variables are probably be co-integrated (Engle & Granger, 1987). Some variables may be moved with the others even though they had been affected by external factors. This phenomenon is long-run relationship between variables. Engle and Granger (1987) presented the approach to detect long-run relation as Engle Granger 2 step approach. Later, Johansen (1988) improved the method based on VAR process as the system-based reduced rank regression approach. The developed approach can be used to indicate the number of co-integration from the hypothesis about the rank of coefficient matrix in the model. However, both approaches remind the important condition of the stationary at the same order of integrated of tested variables. This study applied and considered the co-integration property by Johansen co-integration test as following:

$$\begin{bmatrix} \Delta FDI_t \\ \Delta GDP_t \end{bmatrix} = \begin{bmatrix} \beta_0 & \beta_1 \\ \vartheta_0 & \vartheta_1 \end{bmatrix} \begin{bmatrix} \Delta FDI_{t-1} \\ \Delta GDP_{t-1} \end{bmatrix} + \begin{bmatrix} u_t \\ v_t \end{bmatrix} \quad (5)$$

where $\begin{bmatrix} \beta_0 & \beta_1 \\ \vartheta_0 & \vartheta_1 \end{bmatrix}$ is vector of parameter, $\begin{bmatrix} u_t \\ v_t \end{bmatrix}$ is vector of error term. The co-integration can be accepted

when the rank of coefficient or vector of parameter is not zero. This concept can be proved by rank of vector of parameter with λ_{trace} and λ_{max} eigenvalue value. Null hypothesis of λ_{trace} eigenvalue is the number of co-integration vector which is rank < k while the alternative is rank = k. Null hypothesis of λ_{max} eigenvalue is rank < k while the alternative hypothesis is rank = k+1.

VECM

According to the previous process, long-run relationship of variables was verified by co-integrated testing. This process can be used to extend the property of long-run relation as speed of adjustment running from the deviation of explained variable when the external factor occurred to the long-run equilibrium, the short-run relation, and long-run relation of the interested variables. The method used to analyse is VECM by the followings:

$$\begin{bmatrix} \Delta FDI_t \\ \Delta GDP_t \end{bmatrix} = \begin{bmatrix} A_0 \\ B_0 \end{bmatrix} + \begin{bmatrix} A_1 \\ B_1 \end{bmatrix} EC_{t-1} + \begin{bmatrix} A_2 & A_3 \\ B_2 & B_3 \end{bmatrix} \begin{bmatrix} \Delta FDI_{t-1} \\ \Delta GDP_{t-1} \end{bmatrix} + \begin{bmatrix} p_t \\ q_t \end{bmatrix} \quad (6)$$

where $\begin{bmatrix} \Delta FDI_t \\ \Delta GDP_t \end{bmatrix}$ is constant matrix, $\begin{bmatrix} A_1 \\ B_1 \end{bmatrix}$ is coefficient matrix of error correction component and presented the speed of adjustment of model, $\begin{bmatrix} p_t \\ q_t \end{bmatrix}$ is error term in each model and EC_{t-1} is a vector of error term in

the Johansen test. The long-run relation is accepted when the coefficient of vector error correction was negative significantly. Speed of adjustment is presented by value of parameter in the coefficient matrix of error correction.

Results and Discussion

According to the stationary results from Table 1 to Table 3, it is found that FDI and GDP are non-stationary but stationary at second difference. In Table 1, it can be affirmed that all estimated statistics from ADF-test and PP-test at level are more than the McKinnon critical value. This situation indicated that both variables were non-stationary at level.

Table 1

Stationary Test at Level

Variable	ADF-test			PP-test		
	None	Intercept	Intercept and tending	None	Intercept	Intercept and tending
FDI	2.9654	2.9735	3.5643	11.3005	8.3996	5.5402
GDP	3.2784	19.3751	5.4122	21.5481	21.5332	5.8120

Source: From the calculation.

From the results in Table 2, both variables were non-stationary at the first difference on ADF-test and PP-test. ADF-t statistics estimated by ADF and PP test were less than McKinnon statistic at all.

However, the stationary property was different from the second difference. Table 3 showed that FDI was stationary on ADF test by intercept and tending model and on PP test by without intercept and tending model. Moreover, GDP was stationary on ADF test by intercept model and intercept and tending model as PP test on without intercept and tending model and intercept and tending model.

Table 2

Stationary Test at First Difference

Variable	ADF-test			PP-test		
	None	Intercept	Intercept and tending	None	Intercept	Intercept and tending
FDI	3.0304	2.2941	0.8145	4.7464	3.8086	0.6521
GDP	2.1412	0.2796	-1.5091	3.0666	0.7566	-2.6849

Source: From the calculation.

Table 3

Stationary Test at Second Difference

Variable	ADF-test			PP-test		
	None	Intercept	Intercept and tending	None	Intercept	Intercept and tending
FDI	-0.1936	-0.6431	-3.8541**	-1.6560*	-1.7229	-1.7374
GDP	-2.7317	-7.4286***	-7.3909***	-6.4164***	-8.1668	-13.3229***

Notes. *** significant at 0.01; ** significant at 0.05; * significant at 0.1. Source: From the calculation.

The stationary results shows that FDI and GDP were stationary at the second difference and in the same order of integrated. Thus, both probably detect the long-run relationship by using Johansen co-integration test.

After detecting the stationary property, long-run relation of both variable was proved and presented in Table 4. The result shows that λ_{trace} and λ_{max} were 0.4743 and significantly at 0.05. Moreover, the results indicated that there is 1 co-integration in the system.

Table 4

Co-integration Result

Lag	Eigenvalue		Number of co-integration	
	Trace	Maximum	Trace	Maximum
1	0.4743**	0.4743**	1	1

Note. ** significant at 0.05. Source: From the calculation.

According the VECM results in Table 5, long-run relationship is confirmed by the value in coefficient of EC matrix. There is long-run relation running from FDI to GDP. On the other hand, there is no long-run relationship running from GDP to FDI. The relationship between FDI and GDP will return to equilibrium if there are occurrences by external factor about five percent of the year or about 19 days.

The VECM results conflict the eclectic paradigm of international production of Dunning (2001) in some factor on part of location advantage. Dunning presented that some factor in host country which created the advantage for foreign investor such as host country economy would attract foreign investor to invest on host country. In Lao case, this study was analysed by using the information during 1985 to 2015 (see Appendix 1) which included the effect on the earliest state of foreign investment in Lao as the low value of foreign investment and instability of investment policy while the scale of economy in Lao was very low because there was low domestic investment and saving. Thus, foreign investor was overlooked on the economy factor but attracted by the other factor which made the advantages in Lao. Moreover, this problem made the foreign investment in Laos as an important role for booting the economy presented in the results of VECM.

Table 5

Vector Error Correction Mechanism

Dependent variable	EC	
	Coefficient	t-statistic
FDI	-0.0012	-0.0483
GDP	-0.0518	4.5936***

Note. *** significant at 0.01. Source: From the calculation.

The situation is inconsistent with the effect of human capital and technology and on the relationship from FDI into GDP as Carkovic and Levine (2002) and Borensztein et al. (1998) explained. The foreign investment on the earliest stage is human intensive in the section without more skill labor as Freeman (2002) and Gunawardana (2008) presented. The effect of human capital and technology in this study is not the evidence, although the economic boost policies' implementation has more directly effects on employment than the value added from productivity of human capital or technology. In contrary, the relationship can probably be different if the earliest year is omitted.

Conclusion and Policy Implications

Based on the empirical results, this study found only the effect of FDI on GDP in the long run in case of Laos. The result is inconsistent with the other previous studies and theories because this study included the information in earliest contribute to the effect. As a consequence, the model improvement can be done by neglecting the earliest period estimation.

However, these results confirm that FDI attractive policies of Laos can accelerate economy and stimulate economic growth. Policy makers should concern the other factors to attract FDI as the foreign investment law adjustment to encourage the more transparency competition and the investment promotion policies. Investment tax rate should be lower. The infra-structure of transportation should be more developed. More specifically, it is strongly confirmed that Lao's economy remains high FDI dependent. Laos is natural resources and labor abundant country but low domestic capital formation compared to other GMS neighbor countries. Massive capital from aboard including Thailand moves to Laos to invest in different industries for risk diversification and decreasing cost of production. This policy leads to creating effective regional production hub and network as well as products distribution. Labor skill is crucial support policy implementation to upgrade the human resources potential. FDI in service sectors can be regarded as essential engine to enhance employment. Therefore, trade and investment liberalization and single market under the AEC ultimate goal is the most important supporting element. Furthermore, the effects of FDI in service sectors on employment and economic growth of Laos can be examined by further research to explore the results.

References

- Borensztein, E., De Gregorio, J., & Lee, J. W. (1998). How does foreign direct investment affect economic growth? *Journal of International Economics*, 45(1), 115-135.
- Carkovic, M., & Levine, R. (2002). Does foreign direct investment accelerate economic growth? University of Minnesota, Working Paper.
- Dunning, J. H. (2001). The eclectic (OLI) paradigm of international production: Past, present and future. *International Journal of the Economics of Business*, 8(2), 173-190.

- Engle, R. F., & Granger, C. W. J. (1987). Co-integration and error correction: Representation, estimation and testing. *Econometrica*, 55, 251-276.
- Freeman, N. J. (2002). Foreign direct investment in Cambodia, Laos and Vietnam: A regional overview. Paper prepared for the Conference on Foreign Direct Investment: Opportunities and Challenges for Cambodia, Laos and Vietnam. Hanoi, 16-17th August 2002.
- Gunawardana, P. J. (2008). Trends and patterns of foreign direct investment in Lao PDR. *International Journal of Business and Management*, 3(1), 41-57. doi: <http://dx.doi.org/10.5539/ijbm.v3n1p41>
- Johansen, S. (1988). Statistical analysis of co-integration vectors. *Journal of Economic Dynamics and Control*, 12(2-3), 231-254.
- Kurtishi-Kastrati, S. (2013). The effects of foreign direct investments for host country's economy. *European Journal of Interdisciplinary Studies*, 1.
- Nelson, C. R., & Kang, H. (1981). Spurious periodicity in inappropriately detrended time series. *Econometrica*, 49, 741-751.
- UNCTAD Statistic. (2015). Foreign direct investment. (Online). Retrieved October 20, 2015 from <http://unctadstat.unctad.org/wds/ReportFolders/reportFolders.aspx>
- World Bank. (2016). Lao PDR. Retrieved October 20, 2016 from <http://data.worldbank.org/country/lao-pdr?view=chart>

Appendix 1

Table 1

Gross Domestic Product and Foreign Direct Investment Changing in Lao PDR Since 1985 to 2014

Year	Gross domestic product at 2005 price (US\$ million)	Foreign direct investment (stock) (US\$ million)
1985	899.28	0.55
1986	943.21	0.55
1987	929.76	0.55
1988	911.07	2.55
1989	1,040.36	6.55
1990	1,110.11	12.55
1991	1,157.81	19.45
1992	1,222.18	27.25
1993	1,294.44	57.15
1994	1,400.06	116.35
1995	1,498.5	211.45
1996	1,602.32	371.25
1997	1,712.43	457.55
1998	1,780.37	502.85
1999	1,910.46	554.458
2000	2,021.24	588.348
2001	2,137.49	612.248
2002	2,264	616.748
2003	2,401.36	636.148
2004	2,554.03	653.148
2005	2,735.56	680.848
2006	2,971.34	868.248
2007	3,197.07	1,191.748
2008	3,447.24	1,419.448
2009	3,705.84	1,608.948
2010	4,021.84	1,887.748
2011	4,345.14	2,188.498
2012	4,693.8	2,482.878
2013	5,091.42	2,909.548
2014	5,474.05	3,630.388

Source: CEIC DATABASE (2015).

Analyzing the Roles of Agricultural Extension Agents in Hybrid Rice Technology Decision-Making Process of Farmers, Nay Pyi Taw, Myanmar

Naing Kyi Win, Kyaw Kyaw Win, Cho Cho San, Nyein Nyein Htwe
Yezin Agricultural University, Zeyarthiri Township, Nay Pyi Taw, Myanmar

The study determined the roles of agricultural extension in hybrid rice technology decision-making process by extension agents, Nay Pyi Taw, Myanmar. The specific objectives were: to study personal characteristics of agricultural extension agents, experiences and their roles, to identify extension agents' opinion on hybrid rice technology decision-making process, and to determine relationship between the roles of agricultural extension agents and decision-making process of hybrid rice production. One hundred and eight extension agents were collected who were working in Department of Agriculture, Nay Pyi Taw area and surveyed and interviewed by questionnaires. The study revealed that majority of agricultural extension agents (65.7%) were female staffs and most of extension agents (40.7%) were under 30 years as young staffs. Majority of extension agents (81.5%) were educated only Agri-Diploma. More than half (54.6%) had one to five-year experiences in employment and 58.3% had no hybrid rice training experience and source of information regarding the hybrid rice production was received 63.9% from Department of Agriculture (DOA). Study found that there was highly significant relationship between most of the roles of agricultural extension agents and hybrid rice technology decision-making process of stages 4 and 5. And then most of the extension agents' roles significantly related with stage 2 except role of conducting introduction of hybrid seeds and distribution through by Seed Co. Ltds which was highly significant. Beside, most of the roles of extension agents significantly related with stage 3. However stages 1 and 6 were no significantly related. Finally above all, a well structure seed business, Good Agricultural Practices and farm level mechanization and quality extension service are very important to increase the adoption of hybrid rice in Myanmar.

Keywords: agricultural extension agents' roles, hybrid rice, decision-making process

Introduction

The role of agricultural extension in national agricultural development is pertinent. It has been established

Acknowledgements: Thanks to Department of Agriculture Nay Pyi Taw Council Area, particularly extension agents from respective townships who were working in the field level and admin-staffs. And deserve our sincere appreciation for devoting their time to participating in the field interviews, without them the study would not have been possible.

Naing Kyi Win, Ph.D. student, Department of Agronomy, Yezin agricultural University, Nay Pyi Taw, Myanmar.

Kyaw Kyaw Win, professor and head, Dr., Department of Agronomy, Yezin agricultural University, Nay Pyi Taw, Myanmar.

Cho Cho San, professor and head, Dr., Department of Agricultural Economics, Yezin Agricultural University, Nay Pyi Taw, Myanmar.

Nyein Nyein Htwe, head, Dr., Department of Agricultural Extension, Yezin Agricultural University, Nay Pyi Taw, Myanmar.

Correspondence concerning this article should be addressed to Naing Kyi Win, Department of Agricultural Research, Zeyarthiri Township, Nay Pyi Taw 15013, Myanmar.

that no nation will have real growth in the agricultural sector without effective extension service. Many countries had achieved food security as a result of technology transfer for food crops and farmer capacity building in proper use of natural resources and were facilitated by agricultural extension (Swanson & Rajalahti, 2010).

The agricultural sector is the biggest contributor to the growth of the national economy, the government plays agricultural development at the center of its efforts to build a modern industrialized Myanmar. The agriculture sector of Myanmar contributes 28.6% to GDP and 25.5% to export earnings, and employs 61.2% of labor force (MoALI, 2016). In Myanmar total rice growing area was 17.69 million acres (7.16 million hectare), around 1,300 million baskets (26.73 million Mt) of production and 75.49 baskets of yield per acre (3.9 Mt per ha), in 2016-2017 growing season (Rice Division, DOA, 2017). In Myanmar, there are four groups of rice variety: high yielding variety (HYV), high quality variety (HQV), hybrid variety (HV), and traditional variety. From that on, rice yields and farmers' income would be increased by altering production of hybrid rice, consequently results are alleviating of poverty and better living standard of Myanmar farmers (DOA, 2015). Hybrid varieties have shown 15-20% higher yield potential than inbred rice varieties under farmers' field conditions. It has resistant to drought and salinity however needs to buy seed every season (IRRI, 1991). It could be successful 200 baskets (potential yield) per acre if had systematic and proper care. Within the last five years, around 3% out of total hybrid rice growing areas about over 17 million acres in the whole Myanmar both raining and summer rice growing season have grown. And then gradually, it has declined due to becoming low government intervention. To get superior output production due to the variety change, hybrid rice has the special characteristics such adaptable for local condition, unusual productivity, eating good quality, and better grinding quality when comparing with exemplary rice varieties as Sin Thu Kha, Manawthukha, A Yar Min, and Thee Htet Yin (DOA, 2015).

Agricultural extension division of the Department of Agriculture (DOA) under the Ministry of Agriculture, Livestock and Irrigation is taking part its main task of transferring technologies to the farmers for getting better economic return by increasing yield per acre and improving crop quality. Under DOA, there is "Agricultural Extension Division" which has 9,414 staffs out of 14,774 staffs in DOA. Out of 9,414 which 7,516 are agricultural extension staffs including 6 Ph.D., 25 M.Sc. and 1,680 B.Agr.Sc. and diploma holders. Its major function is transferring appropriate technologies from different resources on the status of farmers. And it also organizes and motivates farmers to adopt proven technologies for better livelihood in rural farming community and increase national agricultural production (Khaing, 2017). Nowadays, DOA is leading to producing the marketable crops which are nutritious and safety. In doing these activities, it conducts the technology transfer by organizing the farmer seed grower association, building the modern villages which used the integrated advanced technology. Implementing this activity, it widely conducts by organizing as the public-private partnership. Moreover, to reach the advanced agricultural technology, information concerned with the climate and market to the farmers in time, it carries out the education programs through the media. On the other side, with the aims of the farmers to use the quality agricultural inputs in line with the rules and regulations, it directly conducts in the fields (AED, 2017).

This study was a part of the research conduct and analyzing the the roles of extension agents which change the attitudes of farmers (beliefs, behaviors, and intervention factors) and decision-making process affecting to utilize the hybrid rice technology. In addition, to building a decision skill of farmers to adopt the new technology, hybrid rice among the Nay Pyi Taw rice farmers is educated by using the extension activities which need to be modified.

Study objectives:

- (1) To study personal characteristics of agricultural extension agents, experiences, and their roles;
- (2) To identify extension agents' opinion on hybrid rice technology decision-making process;
- (3) To determine relationship between the roles of agricultural extension agents and decision-making process of hybrid rice production.

Literature Review

Scarce resources for agricultural production and unfavorable conditions will make it hard to meet future demand in rice and threaten future food security. Hybrid rice technology is a method to increase the productivity of resources needed for rice production. Hybrid rice is the first or second generation derived from a cross between two genetically different parents. The goal is to find a hybrid rice seed that has certain advantages such as higher yields. Hybrid rice can be produced from either japonica or indica varieties. Since rice plants are naturally self-pollinating, i.e. male and female at the same time, and since the breeding of hybrid rice requires control of pollination, one parent line needs to be male sterile. This line does not have viable pollen and is therefore referred to as female and accepts pollen from other rice plants. The other parent line is the male parent line, which is a normal pollen producing parent. There are currently two different methods commercially used to create hybrid rice: a three-line system and a two-line system (Ludwig, 2012). Agricultural extension has played a role in helping to achieve a variety of agricultural development goals (Davis, 2008). Agricultural extension work is a significant social innovation and important force in agricultural change, which has been created and recreated, adapted and developed over the century (Gwyn & Garforth, 1998). The role of an agricultural extension agents helps farmers from sound opinions and make good decisions by communicating with them and providing them with information they need. Opinions and decisions also are based on farmers' values, although, they are not always clear about this relationship, extension also must help them clarify it. Hence the agents can help farmers with their decision-making on their pathway towards knowledge as well as on their path way toward choice (Van den Ben & Hawkins, 1996).

The innovation decision process is the process through which an individual (or other decision-making unit) passes (1) from first knowledge of an innovation, (2) forming an attitude toward the innovation, (3) to a decision or adopt or reject, (4) to implementation of the new idea, (5) to confirmation of this decision. This process consists a series of action and choices over time through an individual (or organization) who evaluates the new idea and decides whether or not to incorporate the innovation into ongoing practices (Roger, 1995).

Myanmar agricultural extension has continuously practiced the traditional extension approach, particularly more on individual contact. This approach has been relying on "progressive farmers" who are generally easiest to reach and have access to sufficient resources land, labor, physical and human capital. It was expected that the adoption of technology by progress farmers would have a trickledown effect on majority of farmers (Oo & Ando, 2012). Hybrid rice program which started since 2011-2012 growing season and government aims to change the varieties like hybrid rice and participate in hybrid rice seed production with private sectors and encourage farmers to have priority in Nay Pyi Taw area and wide spread to nation. At that time extension methodologies which they used by individual, group and mass media methods widely made campaigns in timely manner. In this context, agricultural extension agents applied nine roles as conducting introduction of hybrid seeds and distribution by Seed Co. Ltds, linking input dealers to get the fertilizers and chemicals, supporting farmers with service providers to get farm machinery in time for land preparation, harvesting and

labors for transplanting, connecting between private sector and farmers to do the contract farming, providing market access and price information, accessing credit organizations for investment, conducting the individual contact to promote awareness and adoption of hybrid rice, and conducting meeting, training, demonstration and field days to sensitize farmers, and disseminating information with technology (ICT) such as news paper, radio, television, leaflets, and posters. The conceptual framework, relationship between roles of agricultural extension agents and technology decision-making process is shown in Figure 1.

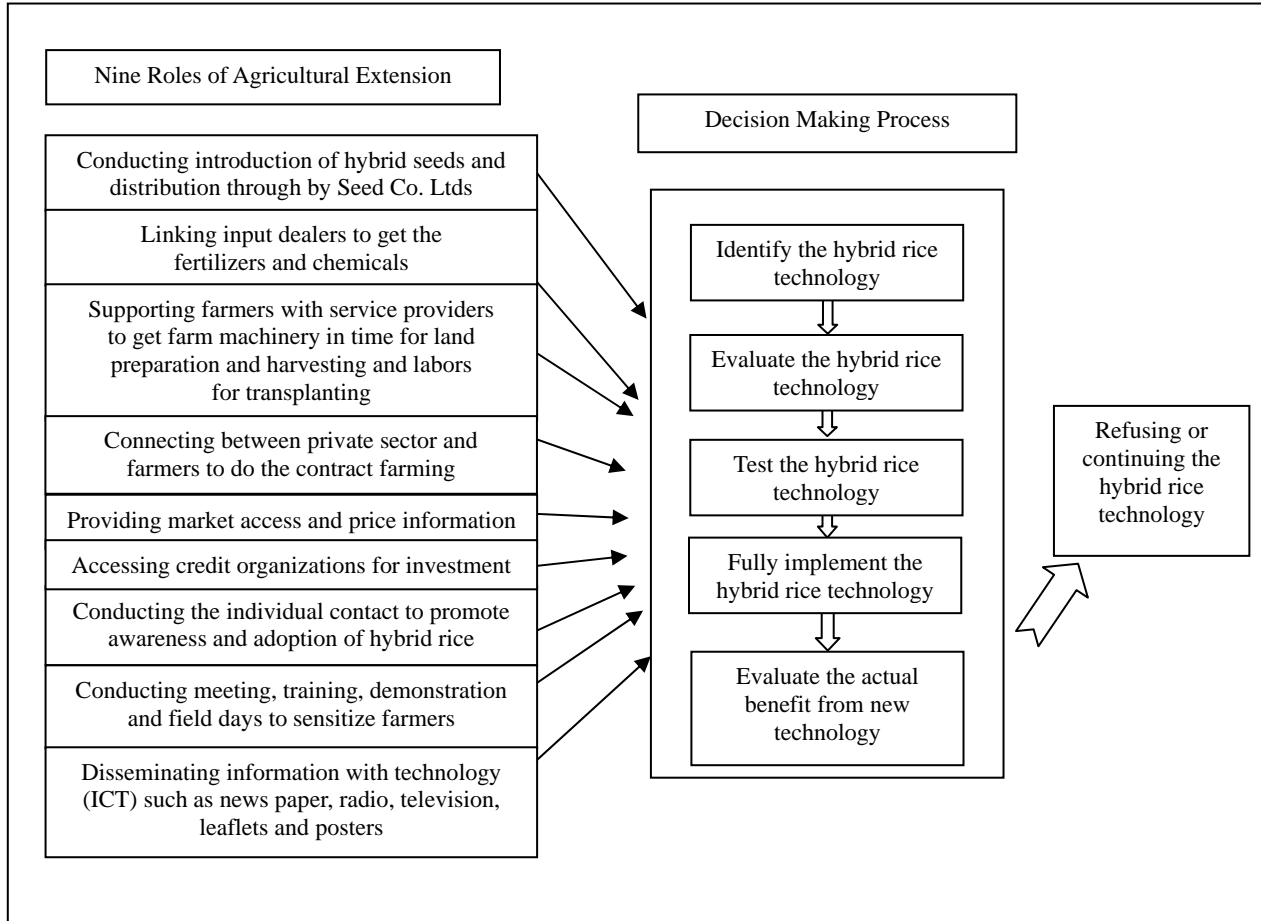

Figure 1. Conceptual framework.

Study Area

Net sown acres of 286,360 including 169,166 acres in Nay Pyi Taw area were paddy growing areas, in which 99,331 farm families were participating in agriculture. Farmers have been growing rice as local, high yield and hybrid and average yield was 87.10 baskets per acre, in 2016-2017 growing year. It has 249 agricultural extension staffs, 18 frontier education camps, and 40 agricultural knowledge centers. Therefore, it can be calculated as agricultural extension agents and farm families’ ratio is 1:400 generally (DOA, 2016-2017). In addition, few NGO, INGO and private inputs Co. Ltds extension workers who were educating non-formal education to farmers. They apply the extension strategy which is conventional and very little participatory approach. Extension agents mostly use meeting, demonstration, field days, distribution of leaflets and pamphlets and broadcast by farmer channel media. The survey was conducted in Nay Pyi Taw area which has private hybrid rice seed production Co. Ltds and started hybrid rice cultivation.

Methodology

This study used survey and interview research design using open and closed questionnaires. The population of the research was 249 extension agents who worked in agricultural extension activities (DOA, 2016). This research mainly selected sample based on supervision of hybrid rice growing farmers and the sample size was 108 respondents including 17 admin staffs and 91 field level staffs. There were included headquarters level and districts and townships level and field level extension agents. Data were collected by using questionnaire and interviewing the 108 extension agents conducted in August to November, 2017. Descriptive statistics were used to describe personnel characteristics of extension agents and experience on hybrid rice and their roles on hybrid rice production. For inferential statistic, Chi-square was employed to determine between independent variables and dependent variables. This study was analyzed by statistical package for social science (SPSS) ver. 16.

Results and Discussion

General Attitudes of Extension Agents to Hybrid Rice Production

Extension agents positively accepted that hybrid rice has more yield advantage than HYV varieties due to the hybrid vigor associated with hybrid rice. Hybrid rice can be grown three times per year because it has shorter duration and greater shock resistances than that with local rice varieties and increase more yield, more income and impact of hybrid rice on food security aspects. They also agreed the social and economic impact feasibility growing hybrid rice. On the other hand, the impacts of technologies were applying the more pesticides and chemical fertilizers which were negative effect to environment. Another crucial disadvantage of hybrid rice is that its produced grain cannot be used as seed for the next season and had inferior quality and competitive market and price compared to local varieties. At the farm level, adoption of hybrid rice might present excessive financial or management constraints due to higher seed costs and different agricultural techniques that are needed. As a positive effect to hybrid rice, government intervention played a major role for diffusion of hybrid rice. Despite its high-yielding characteristic and its tendency for better adaptability to biotic and abiotic stress, adoption of hybrid rice has been delayed.

Personnel Characteristics of Agricultural Extension Agents and Their Experiences

Study resulted that more than half of agricultural extension agents (65.7%) were female staffs. Most of extension agents (40.7%) were under 30 years. Majority of extension agents (81.5%) were educated only Agri-Diploma. More than half (54.6%) had one to five-year experiences in employment, 58.3% had no hybrid rice training exposure and source of information regarding the hybrid rice production received 63.3% from DOA, 29.6% from DAR, 26.9% from IRRI, 17.6% from internet and 14.8% from YAU respectively (Table 1). This study indicated that the main difficulties identified by extension agents regarding technical services providing to farmers were lack of resources, poor knowledge regarding hybrid rice technology, illiteracy among the farmers and communication problems. The most appropriate teaching methods identified by extension agents were demonstration, formal group meetings, and field days. The most frequently methods used by extension agents were farmers meeting and individual contact. The extension agents identified that they need training in improved crop managements, extension managements. Senior extension staffs were their main sources of information of the extension agents. The major difficulties faced by the field assistants were non availability of their office's number of extension workers who had very small, low qualification and

communication skill which need to be improved, similarly pointed out by Farooq, Ishaq, Shah, and Karim (2010).

Table 1

Personal Characteristics Experiences and Source of Information

Personal characters and experiences	Number	Percent
Gender		
Male	37	34.3
Female	71	65.7
Age		
Under 30	44	40.7
33-40	34	31.5
41-50	14	13.0
51-60 (max. =56, min. = 25, average = 14.5)	16	14.8
Education		
Agri-high school	3	2.8
Agri-Diploma	88	81.5
B.Agr.Sc.	15	13.9
M.Agr.Sc.	1	0.9
Ph.D.	1	0.9
Year of employment		
1-5	59	54.6
6-10	11	10.2
11-20	16	14.8
21-30	15	13.9
Above 30	7	6.5
Training experiences		
No training of hybrid rice	63	58.3
One time	28	25.9
Two times	10	9.3
Three times	6	5.6
Four times	1	0.9
Source of information for extension agents		
Department of Agricultural Research (DAR)		
Yes	32	29.6
No	76	70.4
Internet		
Yes	19	17.6
No	89	82.4
International rice research institute (IRRI)		
Yes	29	26.9
No	79	73.1
Yezin Agricultural University (YAU)		
Yes	16	14.8
No	92	85.2
Department of Agriculture (DOA)		
Yes	69	63.9
No	39	36.1

Agricultural Extension Agents' Roles on Hybrid Rice Production

The study revealed that majority (74.1%) extension agents persuaded “conducting introduction of hybrid seed and distribution through seed Co. Ltds” seasonally and 62% of agents served “linking between input dealers and farmers used the fertilizers and chemicals” as much as possible.

And then 50.9% of agents showed the role of “supporting farmers with service providers to get farm machinery in time for land preparation and harvesting and labors for transplanting” and 54.6% of agents interacted “connecting to private sector and farmers to do the contract farming”. Besides, 55.6% of agents supported “providing market access and price information” as rice collectors to buy the rice from farmers and shared the markets information and 52.8% of agents assisted “accessing credit organizations” to get credit. Moreover, majority (84.3%) extension agents applied “conducting the individual contact to promote awareness and adoption of hybrid rice production” and 82.4% of extension agents educated to farmers “conducting meeting, training, demonstration and field days to sensitize farmers” and 73.8% of agents tried to arouse “disseminating information with technology (ICT) such as news paper, radio, television, leaflets and posters”. The success of extension services depends on the role of extension officers to transfer technology and technical competence in developing farmers to increase their productivity (Rahim, 2008). This study pointed out that role of extension agents as change agents is divided into four which encompasses role as catalyst, resource linker, solution giver, and process helper. Based on above finding, there were a wide variety of views on extension agent’s roles (Table 2) which were also supported by Rahim (2008).

Table 2

Roles of Agricultural Extension Agents

Roles of extension agents	Supported		No supported	
	No.	%	No.	%
Conducting introduction of hybrid seeds and distribution through by Seed Co. Ltds.	80	74.1	28	25.9
Linking input dealers to get the fertilizers and chemicals.	67	62.0	41	38.0
Supporting farmers with service providers to get farm machinery in time for land preparation and harvesting and labors for transplanting.	55	50.9	53	49.1
Connecting between private sector and farmers to do the contract farming.	59	54.6	49	45.4
Providing market access and price information.	60	55.6	48	44.4
Accessing credit organizations for investment.	57	52.8	51	47.2
Conducting the individual contact to promote awareness and adoption of hybrid rice production.	91	84.3	17	15.7
Conducting meeting, training, demonstration, and field days to sensitize farmers.	89	82.4	19	17.6
Disseminating information with technology (ICT) such as newspaper, radio, television, leaflets, and posters.	80	74.1	28	25.9

Extension Agents' Opinion on Hybrid Rice Technology Decision-Making Process

This research revealed that all respondents agreed hybrid rice decision-making process diagram flow of farmers and also stage 1 and stage 6 were not constrained for them. Extension agents had explained stage 1, farmers could clearly identify hybrid rice technologies which were educated by using ICT material and upon the stage 6, farmers weighed the positive and negative benefit and consequences and favored the positive outcomes. And then 61.1% of agents showed stage 2 which was not important. In this step, the baseline criteria for judging the hybrid rice technology were set up, for consideration of cost and benefit by supporting the best source information. Extension agents educated to farmers “conducting meeting, training, demonstration and

field days to sensitize farmers”. And also the same resulted that 88.8% of the agents answered stage 3 which was also not important because of supporting the seed to farmers from government subsidy program for testing. Study pointed out that more than half 58.3% of agents felt the fourth stage which also was not important because government encouraged farmers to grow and granted them to buy the product. However, more than half 53.7% of the agents pointed out that the fifth step was important for them (Table 3).

Table 3

Extension Agents' Opinion on Hybrid Rice Technology Decision-Making Process

Statement of the decision-making process	Important stage		Not important stage	
	No.	%	No.	%
Identify the hybrid rice technology	0	0	108	100
Evaluate the hybrid rice technology	42	38.9	66	61.1
Test the hybrid rice technology	12	11.1	96	88.9
Fully employment the hybrid rice technology	45	41.7	63	58.3
Evaluate actual benefit of hybrid rice technology	58	53.7	50	46.3
Refuse or accept continuously the hybrid rice technology	0	0	108	100

Due to the fact that profit is one of the main concerns in every decision-making process, farmers used the judgment principles and decision-making criteria to evaluate. In this step, experience and effectiveness of the judgment principles come into play. Farmers compared with HYV varieties and hybrid rice for their profits and risks.

Relationship Between the Roles of Agricultural Extension Agents and Hybrid Technology Decision-Making Process

This finding revealed that there were no significantly relationships between roles of extension agents against to stage 1 and stage 6. However Chi-square test statistic revealed that stage 2 was related to extension agents' roles as conducting introduction of hybrid seeds and distribution through by Seed Co. Ltds was highly significant. And linking input dealers to get the fertilizers and chemicals, accessing credit organizations for investment, individual and group contact and information technology were significantly related. Stage 3 was high significant with extension agent's roles as connecting between private sector and farmers to do the contract farming. Besides conducting introduction of hybrid seeds and distribution, linking input dealers, supporting farmers with service providers, providing market access and price information, and accessing credit organizations for investment were significantly related. Stage 4 was highly significant with extension agents' roles as conducting introduction of hybrid seeds and distribution through by Seed Co. Ltds, linking input dealers to get the fertilizers and chemicals, supporting farmers with service providers to get farm machinery in time for land preparation and harvesting and labors for transplanting, connecting between private sector and farmers to do the contract farming, providing market access and price information, accessing credit organizations for investment. Moreover, conducting the individual contact to promote awareness and adoption of hybrid rice production, conducting meeting, training, demonstration and field days to sensitize farmers were significantly related. In addition, stage 5 was highly significant to extension agents' roles as conducting introduction of hybrid seeds and distribution through by Seed Co. Ltds, linking input dealers to get the fertilizers and chemicals, connecting between private sector and farmers to do the contract farming, providing market access and price information and accessing credit organizations for investment. Lastly, supporting farmers with service providers to get farm machinery in time for land preparation and harvesting and labors for

transplanting, conducting the individual contact to promote awareness and adoption of hybrid rice production and conducting meeting, training, demonstration and field days to sensitize farmers were related significantly (Table 4).

Research results highlighted the roles of extension agents facilitated in hybrid rice decision-making process of farmers which were insufficiently effective to adopt the hybrid rice production. Among them, research results pointed out that it had constraint to overcome the stages 4 and 5 for extension agents. Farm families have to make a number of different types of decisions, because they face different kinds of problems. Each type requires its own kind of support from agricultural extension. To be able to make good decisions, farmers need information which comes from different sources. They may also need to help to integrate this information, especially when it is conflicting. A problem is that government extension may not be quite competent to provide and not evaluate information on factors influencing market prices, such as quality requirements. The extension agents can give the farmer a recommendation regarding which decision to make or he can guide him with the decision making process (van den Ban, 1988). Pervez, Gao, Zeng, and Uddin (2016) similarly indicated that Chinese hybrid farmers are getting benefit from ICT as e-commerce and internet use and farmers' co-operatives provide a wide range of information on government subsidies, rice cultivation technologies, market information and many other issues which reduce the social and natural risks in agricultural production. Large numbers of public-private partnership (PPP) activities are providing their advisory services at country level and input supports. Creating a positive attitude towards hybrid rice has a significant economic impact on its adoption and also the mass media in the promotion of hybrid rice technology.

Table 4

Relationship Between the Roles of Extension Agents and Hybrid Rice Technology Decision-Making Process

Roles of agricultural extension agents	Hybrid technology decision-making process					
	Stage (1)	Stage (2)	Stage (3)	Stage (4)	Stage (5)	Stage (6)
	Identify the technology	Evaluate the technology	Test the technology	Full implement	Evaluate actual benefit	Refuse or accept continuously
Conducting introduction of hybrid seeds and distribution through by Seed Co. Ltds.	-	16.030***	4.790*	35.265***	38.210***	-
Linking input dealers to get the fertilizers and chemicals.	-	7.978*	8.396*	26.987***	26.800***	-
Supporting farmers with service providers to get farm machinery in time for land preparation and harvesting and labors for transplanting.	-	3.315	9.177*	12.120***	8.300*	-
Connecting between private sector and farmers to do the contract farming.	-	2.588	11.419**	11.324***	10.388***	-
Providing market access and price information.	-	7.013	9.290*	15.427***	14.420***	-
Accessing credit organizations for investment.	-	5.319*	5.206*	14.531***	16.127***	-
Conducting the individual contact to promote awareness and adoption of hybrid rice production.	-	6.246*	0.310	6.942*	10.550*	
Conducting meeting, training, demonstration, and field days to sensitize farmers.	-	5.177*	0.000	6.790*	9.886*	
Disseminating information with technology (ICT) such as newspaper, radio, television, leaflets, and posters.	-	5.053*	0.344	3.542	7.427	

Notes. * Significance level at 0.05; ** significance level at 0.01; *** significance level at 0.001.

Conclusion and Recommendations

This research indicated that most of agricultural extension agents were young and low-experience to extension strategy and methodology and also hybrid rice technology. Sources of information of new technology for extension agents who come down from Department of Agriculture mostly and were supported to farmers by their roles to adopt the hybrid rice technology depend on top down guidelines. On the other hand, they were not to overcome the stages 4 and 5 among the farmers' decision-making to hybrid rice technology. In addition, they mentioned the need of the stable market and farmers wanted to get higher rice price than other varieties repeatedly.

Recommendations were presented as follows:

(1) There should be practiced by doing both extension and technical training to more understand the appropriate extension strategies and methodologies and communication channels.

(2) Extension approach should be changed from conventional to project extension approach with private sector participation and needs to be sustainable after project.

(3) Government should formulate the extension policy in accordance with the requirements of extension agents, farmers, researchers, and private extension workers to be combined approaches.

Finally, above all a well structure seed business and stable market, Good Agricultural Practices, and farm level mechanization and quality extension service are very important to increase the adoption of hybrid rice in Myanmar.

References

- AED (Agricultural Extension Division). (2017). *Annual report of statistic year book*. Department of Agriculture, Ministry of Agriculture, Livestock and Irrigation, Myanmar.
- Davis, K. E. (2008). Extension in sub-Saharan Africa: Overview and assessment of past and current models, and future prospects. *Journal of International Agricultural and Extension Education*, 15(3), 15-28.
- DOA (Department of Agriculture). (2015). Hybrid rice. Unpublished report, Nay Pyi Taw, Myanmar.
- DOA (Department of Agriculture), Nay Pyi Taw area. (2016-2017). *Crop statistical year report*. Unpublished report, Nay Pyi Taw, Myanmar.
- Farooq, A., Ishaq, M., Shah, N., & Karim, R. (2010). Agricultural extension agents and challenges for sustainable development (a case study of oeshawar valley), Pakistan. *Sarhad J. Agric.*, 26(3).
- Gwyn, E. J., & Garforth, C. (1998). *The history, development, and future of the agricultural extension, improving agricultural extension*. A Reference Manual.
- IRRI (International Rice Research Institutes). (1991). *Hybrid rice breeding manual HR2-01-1991*. Los Baños, Laguna, Philippines.
- Khaing, A. A. (2017). Agricultural extension history in Myanmar, "strengthening institutional capacity, extension services and rural livelihoods in the Central Dry Zone and Ayeyarwaddy Delta Region of Myanmar". ACIAR project (ASEM-2011-043).
- Ludwig, T. (2012). Impact of hybrid rice on food security: A spatial equilibrium analysis of global adoption and diffusion of hybrid rice varieties. *Theses and Dissertations*, 444.
- MOLAI (Ministry of Agricultural, Livestock and Irrigation). (2016). Myanmar agriculture sector in brief 2016. Ministry of Agricultural, Livestock and Irrigation, Nay Pyi Taw, Myanmar.
- Oo, K., and Ando, K. (2012). Improving Myanmar agricultural services. Empirical Study View and Perception Field Extension Agents in Mandalay Division Myanmar. Kyoto Working Paper on Area Studies No 123 (G-COE Series 121) January 2012.
- Pervez, A. K. M., Gao, Q., Zeng, Y., & Uddin, M. (2016). Hybrid rice: Bangladesh's failure and China's success. *Journal of Agriculture and Ecology Research International*.
- Rahim, M. S. (2008). Kompetensi dan Amalan Pendidikan Pengembangan (Concept and Practice of Extension Education). Buletin Pengembangan (Extension Bulletin), Bil. 1, University Putra Malaysia.
- Roger, E. M. (1995). *Diffusion of innovation* (4th ed.). New York, London, Toronto, Sydney, Singapore: Free Press.

- Rice Division. (2017). *Annual report of statistic year book*. Department of Agriculture, Ministry of Agriculture, Livestock and Irrigation, Myanmar.
- Swanson, B. E., & Rajalahti, R. (2010). Strengthening agricultural extension and advisory systems. The World Bank, Discussion Paper 45.
- Van den Ban, A. W. (1988). Supporting farmer, decision making by agricultural extension. *Journal of Extension Systems*, 14, 5-67.
- Van den Ban, A. W., & Hawkins, H. S. (1988). *Agricultural extension* (1st ed.). Avon, Great Britain: Bath Press.
- Van den Ban, A. W., & Hawkins, H. S. (1996). *Agricultural extension* (2nd ed.). Blackwell Science.

Local Government Asset Management: Affecting Factors and Policy Implications on Government Work Unit of Central Java Province in Indonesia

Gregorius Nasiansenus Masdjojo, Ratna Sri Kumala Dewi
Universitas Stikubank, Semarang, Indonesia

This study aims to analyze the influence of Human Resource Competence, Regulation, Information Technology, Reconciliation, and Internal Control System on Asset Management in Local Government Work Unit (abbreviated SKPD) of Central Java Provincial Government. This research is conducted because there is still record in the Final Report of Inspection by the Republic of Indonesia Audit Board (abbreviated BPK) concerning problem of asset management conducted by some SKPDs of Central Java Provincial Government, although in general the Local Government Financial Report of Central Java Province has got opinion "Reasonable Without Exception". The data source of this research is primary data collected through interview method on asset management officers at the 48 SKPD in Central Java Provincial Government. Data analysis method used in this research is multiple regression analysis. This research finds that the Human Resource Competence, the Regulation, the Information Technology, the Reconciliation, and the Internal Control System have positive and significant effect on the Asset Management at the Local Government Work Unit of Central Java Provincial Government at level of significance 0.05. Ability to explain of the independent variables to the Asset Management variable is equal to 67.7%.

Keywords: assets management, competence of human resources, regulation, information technology, reconciliation, and internal control systems

Preliminary

The implementation of regional autonomy in Indonesia under the law No. 32 of 2004, increasing consequences of local government authority as a result of the delegation of the affairs was originally done by the central government which is then transferred to the regions. One of them is the change of authority in the management of government assets which was originally mostly handled by the central government. By implementation of the regional autonomy, local governments will receive greater authority to manage their assets. Regional autonomy also had an impact on the demand for public accountability and transparency in the development process of local government management in Indonesia in order to create clean and good

Gregorius Nasiansenus Masdjojo, Dr., MKom, M.Si., lecturer, Faculty of Economic and Business, Universitas Stikubank, Semarang, Indonesia.

Ratna Sri Kumala Dewi, S.E., M.M., post graduate student, Post Graduate Program, Universitas Stikubank, Semarang, Indonesia.

Correspondence concerning this article should be addressed to Gregorius Nasiansenus Masdjojo, Faculty of Economic and Business, Universitas Stikubank, Jl. Kendeng V, Bendan Ngisor, Semarang, Indonesia.

governance (Azhar, 2007).

Law Number 17 of Year 2003 on State Finance Article 1 paragraph 1 states that the State Finance is all rights and obligations of which can be measured by money, and everything in cash, as well as everything in cash or in the form of goods that can be owned by the State in connection with the implementation of rights and obligations. This means that the management of goods can not be separated from financial management.

Given the importance of asset management for the government as well as the amount of expenditures States with regard to the management of these assets, it has become imperative for the government to conduct asset management/state property in a professional, effective, and forward the economic aspects that expenses are right on target, right use, right implementation, and in accordance to legislation in force.

Asset management is actually an integral part of the financial management and is generally associated with the administration of regional development, especially with regard to the value of assets, asset utilization, recording the value of assets in the balance sheet, as well as in the preparation of the priorities in development (Oates, 1995).

Adequate asset management should include the procurement of assets, transferring assets, asset inventory, asset accounting management information systems and accounting sectoral asset, and the preparation of financial statements (Abdullah, Razak, & Pakir, 2011). If all goes well, the process concerning the assets of regional information will be accurate and avoid financial statements disclaimer of opinion (Von Hagen, 2002). Weaknesses that should be corrected is related to weakness associated with assets that can affect CPC opinion among others, yet all the working unit inventory and revaluing its fixed assets. Another factor that needs to be improved is the recording of assets only from capital expenditure for the year so that the assets derived from capital expenditure of the previous year are not accumulated reported, the beginning balance of fixed assets on the balance sheet has not been adjusted for the ending balance audit the previous year so that the final balance sheet after coupled with a mutation of the current year end still displays the data error (Azhar & Darwanis, 2013).

Although the Local Government Finance Report of Central Java province gets an unqualified opinion for three consecutive years, the problem of asset appears as an explanatory paragraph in the opinion for the examination of the fiscal year 2013 and fiscal year 2014. The audit report of the audit board of the Republic Indonesia RI Representative of Central Java Province No. 35A/LHP /BPK/XVIII.SMG/05/2014 Date May 10, 2014 states that land fixed assets are recorded in the balance sheet as of December 31, 2013 by Rp12,05 trillion, there is still a land asset for roads and irrigation which is proof of ownership on behalf of the central government that needs to be validated to ensure the existence and rights of possession. While the audit report of the audit board of the Republic Indonesia RI Representative of Central Java Province No. 35A/LHP/CPC/XVIII.SMG/06/2015 Date June 16, 2015 states that the status of land ownership that has not been validated by the provincial government of the central government and district/city implications for road and bridge assets which are located on the ground also require validation before accounting policy for depreciation is applied.

Based on the above, it is interesting for further study on asset management in the Central Java Provincial Government and the factors that influence it. This research is important to improve asset management in the Central Java Provincial Government. The improvement in asset management of the working unit expected financial reports of Central Java Provincial Government retains the unqualified opinion.

Theoretical Framework

The Definition of Regional Asset Management

Assets according to Government Regulation No. 71 of Year 2010 concerning the Government Accounting Standards are economic resources controlled and/or owned by the government as a result of previous events and from which the benefits of economic and/or social in the future are expected to be obtained, both by governments and society, and can be measured in terms of money, including non-financial resources necessary for the provision of services for the public and resources are maintained for historical reasons and culture. The Government Regulation No. 71 of Year 2010 classifies assets into fixed assets and other assets.

Asset management is the process of managing assets (wealth), both tangible and intangible that has economic value, commercial value, and the exchange rate, to encourage the attainment of the objectives of individuals and organizations. The process of management assets aims to make a profit and to reduce cost efficiently and effectively (Hanis, Trigunarsyah, & Susilawati, 2011).

Asset Management Area is implementing asset management/regional property based on the principle of the basics of asset management to asset by following a policy platform which is governed by the act, government regulations, presidential decrees, ministerial decrees, and decree related to arrangements/asset management area (Wong, 2004).

Factors Affecting the Regional Asset Management

According to Liu (2000), there are five purposes of asset management, namely: the clarity of the ownership status of assets, inventory of area properties and lifetime of assets, optimization of the use and utilization to increase revenues where assets status as idle capacity can be utilized according to the designations assigned, in addition optimized asset utilization can identify and can recognize purpose of those assets, can be intended for anyone and can bring in revenue for asset managers if they can manage assets in accordance with applicable rules, assets management, and basic preparation of trial balance. Factors affecting asset management can not be separated from the elements involved in asset management and author of the report property area.

Based on the flow and the elements of the implementation of asset management, there are five main factors that determine the quality of the effectiveness of the asset management area, namely: (1) Competence of human resources; (2) Regulation; (3) Information technology used; (4) The intensity of reconciliation; and (5) Internal control systems.

Competence of Human Resources

Hanis et al. (2011) described the competence of human resources is the human resource capacity to perform the tasks and responsibilities assigned to him with sufficient provision of education, training, and experience.

Regulation

Regulation is a provision which is used to regulate human relationships in a society or a country . Article 1 paragraph 2 of Law No. 12/2011 on the establishment regulations stated that the legislation was written regulations containing binding legal norms in general and established or designated by the institution or the competent authority via procedures specified in legislation. Regional governments should set itself the management of assets (Article 1 of Law No. 32/2004).

In the context of decentralization, local governments are given the authority to make its own legislation, which must not conflict with higher laws (Article 1 paragraph 5 of Law No. 32/2004). Central Java Provincial Government set Central Java Governor Regulation No. 96 Year 2012 on regional property management guidelines as the basis for the implementation of asset management. Another rule also used as a reference in the area of administration of assets is the Governor Regulation No. 45 of Year 2014 concerning policy and accounting system of Central Java Province with respect to recognition, measurement, and presentation of the assets in the balance sheet.

Information Technology

Technology is a tool that is used by individuals in the completion of their tasks (Goodhue & Thompson, 1995). In the context of information systems, technologies related to computer systems (hardware, software, and data) and the use of support services (training, for example) give the user guide to complete the tasks. The model focused on the influence of specific or general effects of a set of systems, policies, and services rendered by the department of information systems.

In 2013, Central Java Provincial Government in cooperation with SeML System Development Information System and Asset Management (SIM Asset) developed a system of open time or open when there are changes in the basic regulations in implementation. SIM Assets Application refers to the logistic cycle management of regional goods in accordance with the regulations of Ministry of Internal Affairs No. 17 of 2007. System applications are built on line with the method 2 (two) tier which is the client (user) directly related to the database server by using the Internet network (user online) and use the local device through a switch hub (local user). Static IP (Internet Protocol) uses the speedy network owned by Telkom as a destination or address database where data are collected centrally.

Reconciliation

In accordance, Director General of Treasury Regulation No. PER/PB/2009 on Guidelines for Preparation of Financial Statements Reconciliation and Attorney General Treasurer, reconciliation is one of the keys in an effort preparing financial statements credible. This is due to the role that is important in order to minimize the occurrence of differences in recording the impact on the validity and accuracy of the data presented in the financial statements

Reconciliation is done in the framework of the management of the assets in Central Java Provincial Government aiming to obtain the correct value of the assets and valid. Implementation of reconciliation is divided into several stages (Pradono, 2014):

- (1) Reconciliation between board items by preparers of financial statements of the working unit;
- (2) Reconciliation between board items and a rapporteur with DPPAD, coordinator of the local asset manager in Central Java Provincial Government;
- (3) Reconciliation between board items and preparers of financial statements with the accounting section finance bureau as the authors of the report on the financial Central Java Provincial Government;
- (4) Reconciliation between DPPAD with the accounting section finance bureau as the authors of the report on the financial Central Java Provincial Government.

Internal Control System

Government Regulation Number 60 of 2008 defines the Internal Control System of Government is a process that is integral to the actions and activities carried out continuously by the management and all

employees to provide reasonable assurance on the achievement of organizational goals through effective and efficient activities, the reliability of financial reporting, security state assets, and compliance with laws and regulations. SPI is control activities mainly on the management information system that aims to ensure the accuracy and completeness of information

The Relationship of Competence of Human Resources With Asset Management

With the existence of competent human resources and a good understanding about the asset management area, it is expected that a report on education can present a valid asset. Empirical evidence of the influence of human resource competencies in the management of the assets found by Darno (2012) and Hanis et al. (2011) showed that the ability of human resources has positive effect on the quality of goods report and reports quality regional assets. Based on the concepts and empirical evidence obtained from previous studies, the hypothesis 1 is proposed:

H1: Competence of human resources had positive effects on asset management.

The Relationship of Regulation and Asset Management.

To meet the needs of the public on good legislation, it needs to make regulations regarding the establishment of legislation that is implemented in the manner and certain and established method, and standards that bind all competent institutions form of legislation (in the weighing of Law No. 12/2011). In the hierarchy of legislation, laws in force in the area consist of local legislation, regulation, or decision region head and head area.

The influence of regulation on the assets management found by Iqlima showed that each 100% increase in regulation, then in relative terms will also be a positive influence on asset management significantly. Based on the concepts and empirical evidence obtained from previous research, hypotheses 2 is proposed:

H2: Regulatory had positive effects on asset management.

The Relationship of Information Technology With Asset Management

Utilization of information technology that includes computer technology and communication technology in the management of finances and assets is going to improve the processing of transactions and other data, the accuracy in the calculation, as well as the preparation of reports and other outputs in more timely manner. Use of information technology will also help speed up the process of transaction data processing and presentation of financial statements and assets which are government so that the financial statements and the assets of the area do not lose the value of information, namely prudence.

Research of Azhar (2013) showed that the use of information technology has a significant effect in line with the research of Hanis et al. (2011) who stated that the use of information technology has positive influence on the quality of reporting of regional assets. Based on the concepts and empirical evidence obtained from previous research, hypotheses 3 is proposed:

H3 : Information technology had positive effects on asset management.

The Relationship of Intensity of Reconciliation With Asset Management

Reconciliation is one key in efforts to create credible financial statements, in line with these two before the present value of assets in the financial statements to be reconciled in advance either at the internal level the working unit with DPPAD, the working unit with the bureau of finance and DPPAD with the Finance Bureau. With the reconciliation, it can produce accurate data and asset management goes well .

Grubisic (2009) stated that the intensity of reconciliation affects the quality of financial reporting. Based on the concept and empirical evidence obtained from previous studies, the hypothesis 4 is proposed:

H4 : Intensity reconciliation had positive effects on asset management.

The Relationships of Internal Control Systems (SPI) With Asset Management

Internal control is a way to direct, monitor, and measure the resources of an organization, as well as plays an important role in the prevention and detection evasion (fraud). Internal control consists of policies and procedures used in achieving the goals and guarantee or providing reliable financial information, and ensuring compliance with applicable laws and regulations .

Pradono (2014), in his research on “Quality of Local Government Finance Report, Factors Influencing and Policy Implications (Case Study on the Working Unit of the Central Java Provincial Government)”, found a significant effect of the internal control system with the quality of financial reporting. Based on these descriptions , Hypothesis 5 is proposed:

H5: Internal control system had positive effects on asset management.

Research Methods

The population of this research was the manager and/or storage of goods and compilers of financial statements the working unit of Central Java Provincial Government. Target population in this study was an officer/staff directly involved technically in asset management and preparation of financial reporting. The sample was caretaker goods, head of public, and accounting staff preparation of financial statements. The number of samples of each the working unit are 3 (three) so that the number of respondents is 144.

Data Collection Methods

Data were collected through questionnaires that were delivered and taken by researcher directly to some respondents administrators of goods and compilers of financial statements at the working unit. The questionnaires were used to obtain data on the competence of human resources, regulation, information technology, the intensity of reconciliation, and internal control systems.

Data were then analyzed by multiple linear regression method to determine the influence of the competence of human resources (HR) , the regulation (LAW) , the information technology (TIF), the intensity of reconciliation (RKN), and the internal control system (SPI) to the asset management (MA). The regression equation in this study was:

$$MA = \beta_1SDM + \beta_2LAW + \beta_3TIF + \beta_4RKN + \beta_5SPI + \epsilon$$

Results and Discussion

Total of 144 questionnaires were distributed and all have been returned. Validity test of the data was done using factor analysis in which an indicator was valid if it had KMO value of more than 0.5 and the loading factor above 0.4. Based on the validity of the test results, the indicators in the variable MA were invalid because it had a loading factor of 0.383, so that only 20 indicators were included into the next test phase, while in the variable HR, LAW, TIF, RKN, and SPI, all indicators were valid.

From the results of reliability test, Cronbach Alpha value for each variable was MA (0.914), HR (0.908), LAW (0.773), TIF (0.891), RKN (0.928), and SPI (0.894). Because the value of Cronbach Alpha for all the variables was more than 0.6, it could be concluded that the questionnaire used as a measuring tool used in this

study was feasible. Based on tests of normality, it appears that the regression model fulfilled normality assumption. By using the Kolmogorov-Smirnov, it showed the level of significance of the study variables is 0.530.

Then based on Table 1, the multiple regression equation is obtained as follows:

$$\text{MA} = 0.166 \text{ SDM} + 0.161 \text{ LAW} + 0.349 \text{ TIF} + 0.127 \text{ RKN} + 0.186 \text{ SPI}$$

Sig. (0.017) + (0.026) + (0.000) + (0.046) + (0.010)

Table 1

Research Output

Variables	Coeff.	t	Sig.	VIF
SDM	0.166	2.424	0.017	2.082
LAW	0.161	2.254	0.026	2.256
TIF	0.349	4.816	0.000	2.324
RKN	0.127	2.017	0.046	1.765
SPI	0.186	2.602	0.010	2.257
R = 0.830				
Adj.R Square = 0.667				
DW = 1.839				
F = 61.067 (sig. = 0.0000)				

Source: SPSS Research Output (2016).

Hypothesis Testing

Partial hypothesis testing was performed by *t* test by comparing the calculation results with a significance value of 0.05 (rule of thumb).

(a) hypothesis 1

From Table 1 we could see that *t* value of HR was equal to 2.424 with a significance of 0.017 (< 0.05). Therefore, it was proven statistically that HR had a positive and significant impact on MA. Thus, the first hypothesis which states that “The competence of human resources had positive influence on asset management” was accepted.

(b) hypothesis 2

From Table 1 we could see that *t* value of LAW is equal to 2.254 with a significance of 0.026 (< 0.05). Therefore, it was proven statistically that the LAW had a positive and significant impact on MA. Thus, the second hypothesis which states that “Regulation positively influences asset management” was accepted.

(c) hypothesis 3

From Table 1 we could see that *t* value of TIF was equal to 4.816 with a significance of 0.000 (< 0.05). Therefore, it was proven statistically that the TIF had a positive and significant impact on MA. Thus, the third hypothesis which states that “Information technology has positive influence on asset management” was accepted.

(d) hypothesis 4

From Table 1 we could see that *t* value of RKN was equal to 2.017 with a significance of 0.046 (< 0.05). Therefore, it was proven statistically that RKN had a positive and significant impact on MA. Thus hypothesis 4 which states that “The intensity reconciliation positively influences asset management” was accepted.

(e) hypothesis 5

From Table 1 we could see that *t* value of SPI was equal to 2.602 with a significance of 0.010 (< 0.05).

Therefore, it is proven statistically that the SPI had a positive and significant impact on MA. Thus hypothesis 5 which states that “The internal control system has positive influence on asset management” was accepted.

Discussion

The results of this study proved that the competence of human resource, regulation, information technology used, the intensity of Reconciliation, and the Internal Control System were significant factors in the implementation of asset management at the working unit of Central Java Provincial Government.

Human resource is one of the very important elements of the organization, therefore, it must be ensured that the management of human resources is done as possible in order to contribute optimally to the achievement of organizational goals. In governance, particularly in asset management, intellectual ability and physical ability are needed by government officials to secure and optimize their assets. Based on this study, it appears that human resources related to the implementation of asset administration at the working unit mostly have adequate educational competence and have sufficient working time to be able to perform the task well. Nevertheless, some of the working unit still lacks human resources accounting education background that has the task in the presentation of the value of assets on the balance sheet, thus affecting the quality of the reporting of the value of assets.

Regulation is a provision which is used to regulate human relationships in a society or a country. Regulation on local asset management is an instrument of policy and guidelines for asset management area, so it is a basic reference for asset management and implementation in the working unit.

Regulation of the Central Java Governor Number 96 of Year 2012 on Guidelines for Management of Regional and regulations of the Central Java Governor Number 45 of Year 2014 concerning Policy and Accounting System of Central Java Province are used as a reference implementation of the administration, management, recognition, measurement, and presentation of assets on the balance sheet. Both the Governor Regulations are interconnected and not against making it easier for implementers in the implementation of asset management at the working unit.

Utilization of information technology greatly helps speed up data processing transactions and presentation of financial statements and government assets so that the financial statements and the assets of the area do not lose the value of the information that is timeliness. SIM Application Assets Central Java Provincial Government made easily implemented by the managers at the working unit and output from these applications easily obtained at any time because it has been done online.

Reconciliation in Central Java Provincial Government is based on the Central Java Governor Regulation No. 68 of Year 2012 on Standards and Operating Procedures Fiscal Management Central Java Province. Reconciliation with internal and external working unit can identify errors in early presentation of the reporting of assets and minimize the occurrence of correction.

Although the intensity of reconciliation has positive effect on asset management, in reality, there are many working units that are reluctant to perform internal reconciliation. Reconciliation between the board and the items making up the financial statements is done now, which is facilitated by DPPAD as an asset manager in Central Java Provincial Government and the Finance Bureau as a constituent of the financial statements. The working unit has to reconcile before DPPAD and Finance Bureau, so that misstatements presentation and correction can be minimized.

Internal control system of the working unit among other things manage: clearing tasks and responsibilities distribution, implementing mechanisms of reward and punishment, as well as determining the policies and

standard operating procedures in the management of local goods. With the existence of an adequate system of internal control, making the working unit can provide a reliable local goods report for each level of management/leadership as basis for performance evaluation and decision making. More detail, policies, and procedures that are used directly for the purpose of achieving the target in the presentation of the value of assets in the financial statements of the working unit are accurate and ensure observance or compliance with laws and regulations. Although most of the working unit had own rules and regulations about Internal control system, some of the working unit do not have it. Less than optimal implementation of internal control system is the cause of the emergence of the problem assets on LHP of the audit board of the Republic Indonesia on the examination of financial statements.

Policy Implications

Asset management has an important role for the government because it is an integral part of an organization's financial management. Local Government as an organization must conduct the management of state property professionally, effectively, and economically. It is necessary for the expenditure of the costs to be appropriately targeted, appropriately used, and appropriately implemented in accordance with applicable provisions.

Good governance of local government property will certainly facilitate the inventory of local assets. It then becomes an important resource for local governments to support various efforts to increase local revenue. Therefore, it is important for local governments to be able to manage assets adequately and accurately. On the basis of its importance, the implementation of asset management in Central Java Provincial Government needs to get special attention, especially related to the problem of assets that still appears in the Report of Inspection Result by the State Audit Board.

The working unit of the Central Java Provincial Government must immediately improve the quality of its asset management by addressing the constraints and shortcomings during this case. The focus of attention of the manager/leader on improving the quality of asset management are the competence of human resources, the intensity of reconciliation, and internal control systems. It is because these three factors will determine the implementation of good asset management. The evidence suggests that the competence of human resources, the intensity of reconciliation, and internal control systems within the scope of asset management sectors in the Central Java Provincial Government remain inadequate.

The policy that can be done is the structuring of human resources based on the concept of the right man on the right job. Position analysis needs to be done to determine the requirements that are suitable for human resources who will perform the task at a certain position. Through proper human resource management policy, asset management in SKPD will be filled by the right people based on knowledge and skill according to job description in that section. Structuring of the staff of goods in SKPD in Central Java can be started by replacing the old steward with the younger staff and having sufficient education. In addition it is necessary to rotate and disseminate human resources background accounting education to be able to perform tasks as staff compilers of financial statements. The unequal distribution of uneducated accounting human resources will result in reduced quality of asset value representation on the balance sheet.

The development of human resource competencies to the local government can also adopt what has been done by some private agencies/state, where the newly hired employee who first provided education/training/briefing as a basis for future work. What is happening until now is that new employees are

not getting enough stock of knowledge and lack of opportunities for continuing education/training appropriate to the tasks/fields of operation.

The amount of coverage in the region of Central Java Provincial Government requires good coordination between administrators of goods in the working unit mains and auxiliary board staff in integrated services unit of the working unit. This requires internal reconciliation of the working unit. In addition to internal reconciliation on education, it is necessary to establish an external policy of reconciliation between the working unit with Central Government and District/City Government related to assets cooperated and assets donated. This is useful for asset security and clarity area utilization so as to contribute to the acceptance of local revenues. With the clarity of the status of ownership of assets and the amount of value, it is expected that these problems will no longer appear on the audit report of the audit board of the Republic Indonesia.

The element that is no less important is the optimization of the implementation of the internal control system. There are still the working unit, not yet have rules/policy/technical instructions on asset management internally, whereas that the working unit with rules/policy/technical instructions on asset management internally has not been optimally implemented. Optimizing the SPI implementation is important because research shows that the internal control system has a dominant role in asset management of the working unit.

It is necessary to evaluate the effective delegation of tasks related to the management of assets. In the delegation of tasks, users goods in this case, the head of the working unit needs to be really selective in choosing asset management executive staff. Another thing that needs to be done in improving Internal Control System is to conduct an inventory in an orderly manner to the assets owned by providing clear and detailed information on Inventory Item Cards

Conclusion

After testing and analysing data in this study, overall, it can be concluded in accordance with the hypothesis that has been formulated that competence of human resource, regulation, information technology, intensity reconciliation, and internal control systems has positive and significant impact on asset management.

Recommendations

Based on the findings of this study, the following policy recommendations are given:

(1) Placing employees in accordance with the specifications and competence education and providing education/training/technical assistance/courses on asset management for employees/staff regularly and periodically to improve the quality of human resources in the asset manager of the working unit.

(2) Improving the understanding of the existing regulations related to the management of local goods and financial management with an update on regulations change frequently.

(3) Maximizing the use of information technology by improving the ability of employees in using information technology and regularly updating the software and hardware on the use of information technology.

References

- Abdullah, S., Razak, A. A., & Pakir, A. H. K. (2011). The characteristics of real estate assets management practice in the Malaysian Federal Government. *Journal of Corporate Real Estate*, 13(1), 16-35.
- Azhar. (2007). Faktor-Faktor Yang Mempengaruhi Keberhasilan Penerapan Permendagri Nomor 13 Tahun 2006 Pada Pemerintah Banda Aceh. Tesis Universitas Sumatera Utara, Medan.

- Azhar, I., & Darwanis, S. A. (2013). Pengaruh Kualitas Sumber Daya Manusia, Regulasi, dan Sistem Informasi Terhadap Manajemen Aset Daerah (Studi pada SKPD Pemerintah Kota Banda Aceh). *Jurnal Akuntansi Pasca Sarjana Universitas Syah Kuala*, 2, 15-26.
- Darno. (2012). Analisis Pengaruh Kemampuan Sumber Daya Manusia dan Pemanfaatan Teknologi Informasi terhadap Kualitas Laporan Barang Kuasa Pengguna (Studi pada Satker di Wilayah Kerja KPPN Malang). *Jurnal Ilmiah Mahasiswa FEB Universitas Brawijaya Malang*, 1(1).
- Goodhue, D. L., & Thompson, R. L. (1995). Task-technology fit and individual performance. *MIS Quarterly*, 213-236.
- Grubisic, N. M. (2009). *Toward efficient public sector asset management*. Disertasi, Zagreb: The Institute of Economics.
- Hanis, H. M., Trigunaryah, B., & Susilawati, C. (2011). The application of public asset management in Indonesian local government: A case study in South Sulawesi province. *Journal of Corporate Real Estate*, 13(1), 36-47.
- Haryanto, H. (2013). *Pengelolaan dan Akuntansi Keuangan Daerah*. Semarang: Undip Press.
- Liu, J. Y. (2000). Fiscal decentralization and economic growth in China. *Economic Development and Cultural Change*, Chicago, 49, 1-12.
- Oates, W. E. (1995). Comment on "conflict and dilemmas of decentralization" by Rudolf Holmes. *The World Bank Research Observer*, 351-355.
- Pradono, F. C. (2014). Kualitas Laporan Keuangan Pemerintah Daerah Faktor yang Mempengaruhi dan Implikasi Kebijakan (Studi Kasus pada SKPD Pemerintah Provinsi Jawa Tengah). Tesis: Program Pasca Sarjana Universitas Stikubank. Semarang.
- Von Hagen, J. (2002). Fiscal rules, fiscal institutions and fiscal performance. *The Economic and Social Review*, 33(3), 263-284.
- Wong, J. D. (2004). The fiscal impact of economic growth and development on local government capacity. *Journal of Public Budgeting, Accounting and Financial Management*. Fall, 16(3), 799-816.

Socio-economic and Socio-political Effects of Emigration on the Sending Countries

Magdalena Bonev

Walltopia Austria GmbH, Vienna, Austria

Migration is one of the most prominent phenomena in these ultimate years. It has brought some good consequences and economic development, but also a number of socio-economical and socio-political problems, such as decreasing population in the sending countries, brain drain, labour market shortages, etc. This paper focuses on the reasons why people emigrate from their countries of origin and what effects bring their emigration to the national economy. The purpose of the paper is to explain the emigration impact on the labour market in the sending countries, the phenomenon “brain drain” and its effects, the impact of the remittances, and the importance of Diasporas and return migration for the countries of origin.

Keywords: emigration, effects, developing countries, sending economies

Introduction

The study of socio-economic and socio-political effects of migration is a complicated subject, having in mind not only the effects for the receiving country, but also for the sending one. It requires knowledge about the positive and negative aspects of those effects on both sides of migration based on the individual, local, national, and international level.

The net emigration is causing a dramatic decrease in the number of the population in the sending countries and a fall in the country’s labour supply. Much theoretical studies state that the positive and negative effects of the emigration can never be the same for all the individuals in the sending country. To identify the effects—gains and losses to emigration—we need to first clarify whether the emigrant’s well-being and welfare are going to take part in the scenario. One of the early key hypotheses, examining migration states that emigrants are leaving their home lands, driven by the desire for a better living and higher standard of life (Todaro, 1996; Sjaastad, 1962; Harris & Todaro, 1970). One of the leading factors, determining the outcomes of the emigration, is related to the length of emigration, whether it is going to be permanent or temporary. When the emigration is being temporary, it can be assumed that the emigrant’s income is going to lead to a positive outcome for the country of the origin. On the other hand, if we study a case, where the emigration is permanent, we cannot conclude that the outcome will be for sure the same for the sending country. Unfortunately, most of the time, the objects of the study for many authors and analysers are not aware, whether they are going to stay temporary or they will settle down permanently before they migrate. A common practice in nowadays is that the intention of the people leaving is one at the beginning of their journey, but it changes

Magdalena Bonev, Ph.D., Walltopia Austria GmbH, Vienna, Austria.

Correspondence concerning this article should be addressed to Magdalena Bonev, Migazziplatz 5/32, Vienna 1120, Austria.

with the time. It seems that there is a positive correlation between the time spent in the new country and the idea of settling there. The more the person stays away their country of origin, the better the chances are for them to change their mind and consider permanent residence.

The effects of emigration will also depend on the type of the economic in the sending country (whether it is small and open to international trade), the occupations that are being left behind, the remittances, the personal qualification and education (whether emigrants are skilled or unskilled), and the probability of return migration.

Effects of Emigration on the Labour Market in the Sending Country

The empirical data shows that in the traditional countries of emigration, as consequence of the number of emigrants crossing the borders the levels of unemployment are going low, the so-called “export of unemployment” phenomenon. As a result of the lack of working force, the wages are rising. However, labourer’s migration is leading to some negative outcomes for the local labour market. For example, in certain industries, like construction and manufacturing, the number of the qualified and skilled labour force is being significantly reduced. These tendencies are common and most likely to occur in the recently joined EU countries, more specifically Eastern European ones. In many factories, the huge demand on skilled employees is becoming a great challenge for some of the owners and business managers. They also state that those circumstances can cost their company positions in the market and even company existence. The shortage of labour force is increasing dramatically in the sending countries that are experiencing structural imbalance in the labour market. This imbalance is making the task of filling those caused by the emigration “gaps” look impossible. However, assuming that the emigration will result in a higher salary rates, attracting more employees in the certain area, it can assumed that not only the wages will raise, but also employers will be willing to provide training and qualifications for their workforce. The impression of a negative emigration effect can turn in to an advantage in long-term period, affecting both sides of the employment.

Effects of Emigration of Skilled Labour—Brain Drain

When skilled labour emigrates—the so-called “brain drain” phenomenon, the impact on the source country is often considered to be negative. There are couple of reasons for that. First of all, the country of origin is losing the return of its investment in human capital, for example, free education and all other expenses that are being provided throughout the period of raising “the emigrants” when they were growing up. Second of all, highly-educated population will not only get a personal income return by default, but they will also get a high social contribution, such as higher skills, higher wages leading to a higher income taxes, decrease of the child death rates, decrease of the fertility rates, better social and political commitment, voter awareness, etc. On the other hand, when it comes to deciding to emigrate, potential emigrants account for the private gains, perspectives, and outcomes, but will not take into consideration the public and social ones.

The effect of “brain drain” has a specifically negative reflection on the developing countries, where we are not only talking about “brain drain”, but for a classical “brain waste” (Okolski, 2006; Kaczmarczyk & Okólski, 2005). Empirical studies in Eastern European countries prove that the foreign companies, investors in the local markets are experiencing serious problems when trying to find and hire skilled candidates.

Many authors’ attention is caught by the fact that whether the emigration of highly qualified labour force has a negative impact is not as simple as the reasons seem to indicate. First, the public investment in human capital may be relatively small. In many cases, much of the expenses related to the education might have been

paid by the individual or by their family. In fact, individuals may invest in human capital aiming emigration at first place, earning the return on investment in the country recipient and retrieving part of the income gained in the foreign country into the homeland. In the given situation, the return on the investment may come in the form of remittances, sent by the emigrant. Often the amount being sent monthly is exceeding the potential income of the individual if they have not decided to emigrate. Taking into consideration that the emigration could be temporary, rather than permanent, the return of any public investment may come in the form of physical capital that the emigrant returns when he/she comes back in the country of origin. Last, but not least stays the fact that the loss of any social returns on investment in human capital, invested by the public sector, indicates a greater problem than the “brain drain”. The fact that the individual will only take into consideration their own personal outcomes of the effect caused by their emigration and will not think about the reflection of it on social and public outcomes, suggests that the society is not investing enough in developing the country. There are certain forms of control and prevention of the emigration that would limit the “brain drain”, but they will not be a solution to the problem caused by the lack of investments.

The discussion suggests that the losses to the source country will be positively related to the amount of emigrant’s human capital investment that is paid by the public sector. However, such losses will be offset by any remittances sent by the emigrant, who left his/her country of origin, or by any physical capital that returns with the emigrant. In fact, as noted by Lucas and Stark (1985), families with poor access to capital markets may invest in their children, so they can emigrate and later remit some funds.

Remittances Impact on Sending Economy

Some of the emigrants are sending part of their income to relatives in the country of origin. The money retrieved in the sending country partly or fully compensates the lost income in the household because of the emigration. As noted by Stark (1991), the emigration and remittances may be jointly determined by the family as a way of family income diversification. Families insure by spreading “household members across markets, where income fluctuations are not positively correlated” (Lucas, 1988, p. 126).

Another interesting issue is whether the money transfer is being used for consumption or the exact opposite, being invested or accumulated on a savings account/investment. Kindleberger (1967, p. 94) and Castles and Kosak (1973) all suggested that the foreign financial income, which is being used for domestic needs, are not contributing enough to the development of the sending country. Having in mind the statements above, it can be assumed that the use of the remittances for financing the personal use of the individual, rather than investing, is a negative aspect of the emigration.

However, empiric research outlines the significant effect of remittances on the developing economies in various ways. The main debates about the impact of remittances on growth refer to the use of remittances for productive investment that would contribute to long-run development. But impact on economy should be viewed not only from the point of view of remittances-investment relationship. In fact, remittances can affect positive economy in some of the following ways:

- Management of remittances by bank;
- Extension of investment credit allowed by the increase in the liquidity of banks from remittance deposits;
- Investment in human capital in the form of spending on certain consumption items as education, health, etc.;
- Smoothing income inequality in short-term and diversification;
- Growth in investment as a result of the multiplier effects of spending on consumption;

- Influence disposable income for investments, savings, and consumption;
- Decreasing poverty, especially in developing countries with high remittances to GDP flows.

Money transfers reach directly the households that need it. As a result, it has to be mentioned that whatever needs are addressing, be it consumption, investments, debt reimbursement, or covering survival expenditure in general, remittances represent an undoubted benefit, being able to satisfy directly household needs.

Social and Socio-political Effects of Emigration

A serious problem, caused by the increased levels of migration flows, is the depopulation of certain areas of the countries, especially regions that are close to the state borders. Combined with the typical for these regions low mobility of the human capital, the depopulation leads to dramatic regional differences, also in terms of the unemployment levels. In theory, one can expect that the experience and the “adventures” of the emigrants, representing the most mobile part of the population, could possibly contribute to increase the local population’s mobility.

One of the significant emigration effects is the rising labour market reforms opportunity for the sending country. If the market is facing high levels of unemployment, this means that there is structural market deficiency observed. Given those circumstances, it will be hard for the source country government to make any reforms. On the other hand, steady labour market can provide an opportunity of making the necessary adjustments.

One of the main social issues in the sending economies caused by the increased emigrational flows and their age and gender specifications is the separation of the family and in many cases the elders left behind. Many women are separated from their partners and children suffer too from the absence of their fathers. Perhaps, one of the most serious problems concerns elderly people, who lost their family and social support. There are many emigrants strategies that include the old people “in the plan” of going and settling in the receiving country. The parents follow their children abroad to provide childcare for their grandchildren, enabling both the working-age parents to engage in paid work. Unfortunately, there are also plenty of cases with elders left behind in the small villages. The last phenomenon is called “elderly orphans”. Regardless of the fact that the remittances make the social discomfort bearable enough, the lost of the family (children and grandchildren) takes part in their psychological and emotional self-esteem.

Other evidences show that in some cases children are being left in the country of origin and being raised by their grandparents. The idea behind is providing better future for the youngsters. Even though the intentions are completely innocent, this scenario often ends in a situation where the child becomes spoiled or problematic. Many kids in that situation drop out of school. Those social effects correlate directly with the future return on human capital investment and economic development of the source countries.

Effects on Sending Country Caused by the National Diasporas Abroad

The subject of national Diasporas and the issues around it are being neglected for years. With the expansion of emigration flows, they took the media and recently even the politics attention, especially in the developing countries. The most popular representation of Diaspora is very shallow and unsophisticated. The opinion and knowledge about the Diaspora in the sending countries is mostly influenced by the answers of some certain questions, like “Did they succeed ‘there’ or not?”, “Do they love their country?”, “Do they visit

back or not?”. The expectations from the emigrants communities is to support their families by sending money back home, but not to take part in decisions on any political or other issues at home or even have an opinion on it. A generalization, like this, prevents an adequate political strategy of getting the Diaspora involved in the economy in the country of origin and also getting the best of their experience abroad.

One of the positive outcomes that could be derived from the emigration of the highly qualified people is gathering them in one well-educated national Diaspora. It has already been mentioned that the individual contribution to the sending country is mostly related to the financial support to the family. However, the contribution from the Diaspora would have a bigger influence. Presented as a single idea, regardless of the position and the education of the individual, it will not be able to take place in a decision in the country of origin. But the Diaspora would be able to use the accumulated opinion and influence the processes not only in the source country, but also in destination country. China, India, and Taiwan, for example, are some of the countries accomplishing good results using their Diasporas in the national further development. All of these countries have been establishing businesses and educational systems that include their communities abroad and they are protecting their national interests abroad. One of the factors determining the participation of the Diaspora in the national issues is the trust in the government in the country of origin. Corruption is one of the first associations with the home government for many of the emigrants from the traditional source countries. That seems to be one of the reasons why people abroad are more willing to support people non-related to an organisation regardless of whether they are part of the family or not. To succeed in any of its initiatives, the country needs to establish trust in its government. Here are some of the suggestions of a good politics and ways of achieving that:

- Acknowledgment of the emigrant’s contribution to the country;
- Establishing a systematic support, protection, and stepping in for the rights of the emigrants and their families;
- Contributing and supporting the expansion of the national culture in the foreign countries;
- Social and intellectual network development.

Return Migration

Part of the emigration is not permanent, but temporary. Usually emigrants that are returning home, invest in their future back in the sending country (in most of the cases by starting own small business). It seems that they accomplish more for a short period of time abroad and it is most likely that they would not be able to do this if they have not left their country of origin.

Some of the developing sending countries, for example, East European ones, will continue to record higher mortality rates, lower fertility rates and higher level of emigration rather than immigration (net emigration countries). The demand on working force will continue to rise, and thus, the return migration will play an important role in the future economic development of these countries. Many social benefits can attract the emigrants to return, for example, the ability to transfer the accumulated pension from the foreign country and health insurance. The government politics, managing the temporary migration, could be used to take some opportunities provided by other countries, regarding investment in the young population’s abilities and skills—seasonal migration, educational programs, internships, etc.

As a last point of the paper, it is worth mentioning the social consequences of the circular and temporary migration. Even though there are many positive impacts for both the sending country and receiving country, in

many cases the price paid by the emigrants is significant. They move from one country to another, experiencing different social and cultural standards, stress, isolation, and homesickness. Emigrants are being part of more than one country and at the same time they get confused to which country they belong.

Conclusion

Sending countries are assuredly gaining many and different aspects of positive and negative effects on them caused by the emigration. Some of the impacts are contributing to the future economic development of the country and the economy, for example, return migration, remittances, and national Diasporas. Others like brain drain, brain waste, labour market shortages, and depopulation cause negative influence on the source country. How the drop in population and labour supply affects the source country's economy is varied. In general, the results would be different in the different countries and they will be depending on the type and size of the local economy. The emigration impact will also relate to the number of emigrants and their personal life, goals, and beliefs.

References

- Castles, S., & Kosack, G. (1973). *Immigrant workers and class structure in Western Europe*. Institute of Race Relations, London, Oxford University Press.
- Chandavarkar, A. G. (1980, June). Use of migrants' remittances in labour-exporting countries. *Finance and Development*, 17(2), 36-39.
- Domingues Dos Santos, M., & Postel-Vinay, F. (2003). Migration as a source of growth: The perspective of a developing country. *Journal of Population Economics*, 16(1), 161-175.
- Economic and Social Commission for Asia and the Pacific. (1987). *International labour migration and remittances between the developing ESCAP countries and the Middle East: Trends, issues and policies*. Bangkok: United Nations.
- Harris, J., & Todaro, M. (1970). Migration, unemployment and development: A two sector analysis. *American Economic Review*, 60(1), 126-142.
- Kaczmarczyk, P., & Okólski, M. (2005). International migration in Central and Eastern Europe—Current and future trends. *UN Expert Group Meeting on International Migration and Development*, United Nations, New York, 6-8 July (UN/POP/MIG/2005/12).
- Kindleberger, C. P. (1967). *Europe's postwar growth: The role of labour supply*. Cambridge, MA: Harvard University Press.
- Lucas, R. E. B. (1981). International migration: Economic causes, consequences, and evaluation. In M. Kritz, C. Keely, and S. Tomasi (Eds.), *Global trends in migration: Theory and research on international population movements* (pp. 85-109). New York, NY: Center for Migration Studies.
- Lucas, R. E. B. (1988). Guest worker emigration and remittances. In D. Salvatore (Ed.), *World population trends and their impact on economic development* (pp. 125-138). New York, NY: Greenwood Press.
- Lucas, R. E. B., & Stark, O. (1985). Motivations to remit: Evidence from Botswana. *Journal of Political Economy*, 93(5), 901-918.
- Katseli, L. T., Lucas, R. E. B., & Xenogiani, T. (2006). Effects of migration on sending countries: What do we know? Working Paper No. 250. Paris: OECD Development Center.
- MacMillan, M. J. (1982, March). The economic effects of international migration: A survey. *Journal of Common Market Studies*, 20(3), 245-267.
- Okolski, M. (2006). Costs and benefits of migration for Central European countries. CMR Working papers, Formerly ISS Working papers, Seria; Prace Migracyjne, No 7/65.
- Sjaastad, L. (1962). The cost and returns of human migration. *Journal of Political Economy*, 70(5), 80-93.
- Stark, O. (1991). *The migration of labor*. Basil Blackwell, Cambridge.
- Todaro, M. P. (1996). *Economic development* (6th ed.). Addison-Wesley 1740.

A Brief Analysis of Option Implied Volatility and Strategies

Zhou Heng

University of Adelaide, Adelaide, Australia

With the implementation of reform of financial system and the opening-up of financial market in China, knowing and properly utilizing financial derivatives becomes an inevitable road. The phenomenon of B-S-M option pricing model underpricing deep-in/out option prices is called volatility smile. The substantial reasons are conflicts between model's presumptions and reality; moreover, the market trading mechanism brings extra uncertainties and risks to option writers when doing delta hedging. Implied volatility research and random volatility research have been modifying B-S-M model. Giving a practical case may let reader have an intuitive and in-depth understanding.

Keywords: financial derivatives, option pricing, option strategies

Introduction

Since the first standardized “exchanged-traded” forward contracts were successfully traded in 1864, more and more financial institutions and companies were starting to use financial derivatives not only for generating revenue, but also aiming for controlling the risk exposure. Currently, derivatives can be divided into four categories which are forwards, options, futures, and swaps. This essay will mainly focus on options and further discussing what causes the option's implied volatility and how to utilize implied volatility in a practical way.

Causing the Implied Volatility

Implied volatility plays an important role in valuing an option, and it is derived from Black-Scholes option pricing model. Several theories explained the reason.

Market Trading Mechanism

Basically, deep-out of money options have less probability to get valuable comparing with less deep-out of money options and at-the money options at expiration date. Therefore, generally deep-out of money options will be valued less than other options. It is becoming desirable for market investors because of its capacity to become valuable and relatively cheap. Overall, deep-out of the money options will have a higher implied volatility, moreover according to put-call parity theory, deep-in the money options will have a higher implied volatility as well.

The Difference Between Reality and Assumption of Black-Scholes Model

Under assumption of traditional Black-Scholes option pricing model, it assumes that return of financial underlying assets follows a normal distribution. Nevertheless, massive data analyzing illustrate that, in reality, the financial underlying asset's return follows a log normal distribution. Under log normal distribution, the

Zhou Heng, degree of bachelor, School of Business, University of Adelaide, Adelaide, Australia.

Correspondence concerning this article should be addressed to Zhou Heng, 6/112 Gilbert Street, South Australia 5000, Australia.

probability of occurring an extreme value is greater than in the normal distribution. Hence, traditional B-S-M model will generally underestimate value of the deep-out of money option and deep-in the money options simultaneously.

Case Demonstration

Briefly BHP (BHP Billiton Limited) stock call options are used to give an example how to apply volatility arbitrage. Aiming to maximize profit, in general puts of the same strike price are priced higher than call options, including the stock trend speculation and the B-S-M framework, and the report will mainly observe out-of-money call options.

Observations

We observed BHP (BHP Billiton Limited) Jun 30, 30.5, 31.5, 32, 32.5 five out-of-money BHP call options with the same time to expiration though varying strike prices from April 3rd, 2018 to April 18th, 2018. After calculating the implied volatility (IV) using a software, we graphed the plots and discovered a volatility skew initially, and higher strike price options have lower IV than lower strike price options. Such infers investors are expecting the probability of underlying price surpassing \$30 is on a decreasing trend. The phenomenon suggests an arbitrage opportunity as of the aforementioned B-S-M framework, where the calls would be highly demanded.

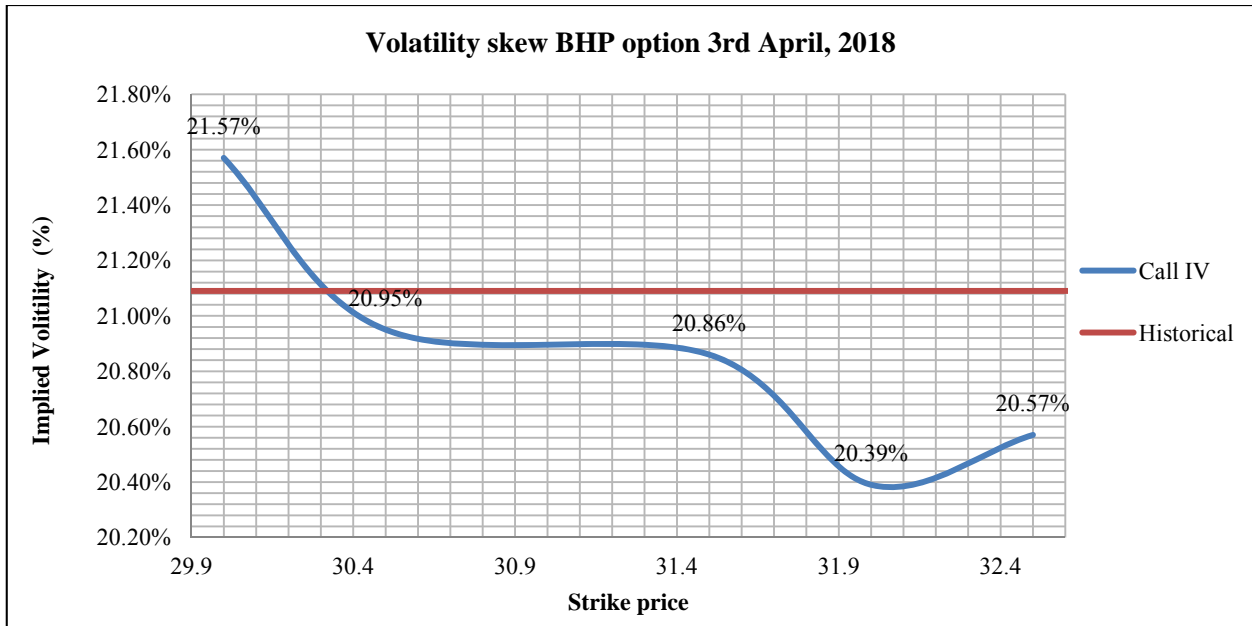

Figure 1. BHP option volatility skew on 3rd April, 2018.

On 3rd April, the calculated call option was overpriced by using mean reversion analysis. BHP stock average return historical volatility from 26th April, 2017 to 29th March, 2018 was 21.089%, smaller than the current call’s IV inferring the call being overpriced. As option is derivatives of its underlying, we can compare underlying assets historical volatility with option’s implied volatility to determine whether it is fairly priced or not; the greater the difference between implied volatility and historical volatility, the greater profit from volatility arbitrage.

Table 1

Comparing Implied Volatility and Historical Volatility(3rd April, 2018)

BHP Jun 18, 30	3rd April, 2018
Implied volatility	0.2157
Historical volatility	0.2109
Difference	+0.0048

Strategy

Planning

According to the mean reversion theory, price of an extreme overpriced or underpriced security will invert to its average price over a time, together with the speculations of the increasing trend of the recent stock price previously mentioned, hypothetically the assigned overpriced option should drop to average price. The strategy involves trading against the skew, when the option reverts to a fair price level, it will be bought back to earn profit.

The strategy of choice was delta hedging. To construct a delta neutral portfolio, we need to calculate the number of stocks by utilizing B-S-M model for hedging assigned call.

Notation:

Table 2

BSM Variables(3rd April, 2018)

Stock price (S_0)	Strick price (X)	Risk free rate (r_f)	Standard deviation (σ)	Time to expiration (T)
\$28.71	\$30	2.81%	0.21557	$\frac{76}{252}$

S_0 , X , σ , and T are obtained from the AFR (2018); risk-free rate is from Australian bond. Noting T is in trading days.

Calculations suggest each one call short should compensate with long 0.4052 stocks to hedge delta to zero. Thus 10,000 BHP Jun 18 calls were short and long 4,052 BHP stock as the opening position. Choice of broker was Westpac with transaction costs consisting of 0.11% gross value basis charged in stocks trading, 0.35% gross value basis charged, and \$0.31 per contract clear fees in options trading (Westpac, 2018).

$$\begin{aligned} \text{Initial investment cost} &= 10,000 \times \$0.9(1 - 0.0035) - 4,052 \times \$28.71(1 + 0.0011) \\ &= -\$107,492.39 \end{aligned}$$

Implementation

(1) Week one portfolio value summary:

One week after, increasing in portfolio value (π) calculation on 11th April is as follows. Current option price is at \$1.14 and BHP stock price is at \$29.44 per share. Call price increased from \$0.9 to \$1.14 and stock price increased \$0.17 per share. Stocks contribute to Week one profit due to initial position but greater call price consumes portion portfolio value.

$$\begin{aligned} \pi &= -10,000 \times (\$1.14 - \$0.9) + 4,052 \times (\$29.44 - \$28.71) \\ &= \$557.96 \end{aligned}$$

Portfolio adjustment:

The implied volatility has changed as follows:

Table 3

Comparing Implied Volatility and Historical Volatility (11th April, 2018)

BHP Jun 18, 30	11th April, 2018
Implied volatility	0.2158
Historical volatility	0.2109
Difference	+0.0049

On 11th April, the new stock price (S_t) is \$29.44, and delta has become volatile demanding for adjustments. Applying BSM model:

Table 4

BSM Variables(11th April, 2018)

Stock price (S_0)	Strick price (X)	Risk free rate (r_f)	Standard deviation (σ)	Time to expiration (T)
\$29.44	\$30	2.81%	0.2158	$\frac{68}{252}$

Extra 788 BHP long stock positions are required for maintaining the delta.

$$\begin{aligned}\text{Adjustment cost} &= -\$29.44 \times 788 \times (1 + 0.0011) \\ &= -\$23,224.2\end{aligned}$$

(2) Week two portfolio value summary:

The implied volatility has changed as follows:

Table 5

Comparing Implied Volatility and Historical Volatility(18th April, 2018)

BHP Jun 18, 30	18th April, 2018
Implied volatility	0.1905
Historical volatility	0.2109
Difference	-0.0204

The call price and stock price at 18th April are \$1.24 and \$30.70 respectively. The profit is based on current position with new price (write 10,000 calls and long 4,840 stocks):

$$\begin{aligned}\pi &= -10,000 \times (\$1.24 - \$0.73) + 4,840 \times (\$30.70 - \$28.88) \\ &= \$659.60\end{aligned}$$

Despite call price increased significantly offsetting returns from stocks, a \$659.60 gain was realized.

To close out, the inverse sequence of operation takes place. Originally, the portfolio consists of short 10,000 calls and long 4,840 stocks, and amendments are as followed: long back 10,000 calls at \$1.24, selling out 4,840 stocks at \$30.07 while paying off transaction fees. Profit calculation is shown below:

$$\begin{aligned}\pi &= -10,000 \times \$1.24(1 - 0.0035) + 4,840 \times \$30.07(1 - 0.0011) - 10,000 \times \$0.13 \\ &= \$131,635.30\end{aligned}$$

Trading Profits Summary

Initially, \$107,492.40 was invested, receiving \$131,635.30 in the end. During the first trading week, \$557.96 was realized; in first date of second week adjustment was made costing \$23,224.2, concluding with a gain of \$659.60. Total return is:

$$\pi = -107,492.4 - 23,224.2 + 131,635.3 = \$918.7$$

$$\begin{aligned}\pi &= -\$107,492.40 - \$23,224.20 + \$131,635.3 \\ &= \$918.7 \\ \frac{918.7}{130,716.6} &= 0.7\% \text{ yield}\end{aligned}$$

The whole trading yielded 0.7% profit over two weeks.

Evaluation

Overlook

Delta hedge and volatility arbitrage strategies earned a 0.7% return in two weeks which is relatively insignificant to professionals. Theoretically, delta hedge portfolio would provide a risk-free return plus arbitrage profit, based on the option price volatility and inherent drawbacks of delta hedge strategy. The IV graph plot for each option declined on varying scale. The general decline is likely the effect of lost in time value, thus option value decreases, compensating IV would also fall. Though further evaluation then suggests an anomaly, on 18th April the call had an IV of 0.1905, lower than the historical volatility of 0.0204, contrasting to its price of \$1.04 being higher than our initial option price with higher implied volatility. The phenomenon breaches the theory, an unanticipated incident in past time, inducing \$3,400 loss.

Improvement for Strategy

By hind side, knowing option price would rise after two weeks; the strategy would long 10,000 calls waiting to short them at a higher price two weeks later, simultaneously short sell 100,000 delta numbers of BHP stocks to reduce calls exposure risk.

Delta Hedge Strategy Assessment

The intention was to identify an overpriced option, write it first, and then buy back to gain arbitrage profit; such provides hedging exposure risk from short positions and is a simple strategy to execute. Calculation based on real data illustration of our delta strategy is profitable though results suggest otherwise. Profit from delta hedge is smaller than risk-free return, mainly due to the absence of hedging Greeks neutral, e.g., Rho neutral, Vega neutral, Theta neutral, and Gamma neutral. Moreover, delta hedge only hedges against minor changes in underlying asset price, thus in practice it requires constant adjustment and often should be accompany with other Greeks for a more practical strategy.

Improvement on Delta Hedge Portfolio

A Gamma neutral portfolio could compliment the above mentioned drawbacks. Gamma neutral represents delta on a larger scale, thus more suited for larger underlying movements. To achieve such, the portfolio gamma and delta value are required then applying the formula $w_T = \frac{-\gamma}{\gamma_T}$ then $\Delta_T \times w_T$ to buy or sell the number of shares to obtain delta neutrality, or simply hedge the gamma of two options accordingly to a ratio.

Relative Volatility vs. Absolute Volatility

It is popular to utilize volatility-orientation strategies to make profits when trading options in the markets. Volatility smile and Gamma are both volatility-orientation strategies for the purpose.

A similarity between the two strategies is that they both use volatility as measurements. Volatility smile is the plot of the implied volatility of an option with the same maturity as a function of its strike price (Hull, 2012,

p. 409). Volatility smile defines the relationships between implied volatility and strike price, enabling traders to use volatility smile to set option prices (Hull, 2012, p. 420). The Gamma of a portfolio of options is the rate of portfolio's delta change with the change of underlying assets price (Hull, 2012, p. 389). When Gamma is calculated, the equation is $\gamma = \frac{e^{-d_1^{2/2}}}{S_0 \sigma \sqrt{2\pi T}}$. The value of volatility (σ) is used for this equation.

In contrast, Delta and Gamma hedging are both based on the assumption that underlying assets' volatility is constant whilst volatility smile/skew assumes a dynamic movement. The Greek's volatility is more likely to be historical volatility because it is calculated based on recent data similar to an absolute volatility value. In practice, the volatilities are changing frequently and traders also need to constantly rebalance the portfolios to maintain delta neutrality. Such may seem more practical to use relative volatility of skew/smile to depict non-log normality trends.

Conclusion

As time flows, financial market substantially plays a more significant role in an economy. Especially for current Chinese economy, as the world's second largest economy, financial market scale also ranks third in the world. However, the financial internationalization level, regulation level, and business development level cannot satisfy the current demand of Chinese economy. Moreover, it also does not accord with China's robust economic growth, the increasing number of middle classes, wealth increases, and ageing populations. Therefore, comprehensively promoting financial reform and domestic market internationalization is an inevitable trend. Knowing financial derivatives and introducing financial derivatives into Chinese market become a necessary way in the future.

References

- AFR. (2018a). *Australian Share market trading data for Tuesday*. Retrieved on April 3, 2018 from <http://www.afr.com/share-tables>
- AFR. (2018b). *Australian share market trading data for Monday*. Retrieved on April 9, 2018 from <http://www.afr.com/share-tables>
- AFR. (2018c). *Australian share market trading data for Monday*. Retrieved on April 16, 2018 from <http://www.afr.com/share-tables>
- Hull, J. (2012). *Options, futures, and other derivatives* (8th ed.). UK: Pearson Education.
- Icngateway. (2018). *BHP—South Flank iron ore project*. Retrieved on 6th April, 2018 from <https://gateway.icn.org.au/project/3905/bhp-south-flank-iron-ore-project>
- McKinnon, S. (2017). BHP begins early work at \$US3.2b South Flank project. *The West Australian*. Retrieved on 6th April, 2018 from <https://thewest.com.au/business/mining/bhp-begins-early-work-at-us32b-south-flank-project-ng-b88518020z>
- Statista. (2018) *BHP billiton—Statistics & facts*. Retrieved on 6th April, 2018 from <https://www.statista.com/topics/3401/bhp-billiton>
- Trading Economics. (2018). *Australia government bond 10Y*. Retrieved on 3rd April, 2018 from <https://tradingeconomics.com/australia/government-bond-yield>
- Westpac (2018). *View fees & charges*. Retrieved on 4th April, 2018 from <https://onlineinvesting.westpac.com.au/Public/FeesAndCharges/FeesAndCharges.aspx>
- Yahoo Finance. (2018) *BHP billiton limited (BHP.AX)*. Retrieved on 3rd April, 2018 from <https://au.finance.yahoo.com/quote/BHP.AX/history?p=BHP.AX>



Economics World

Volume 6, Number 4, July-Aug. 2018

David Publishing Company

616 Corporate Way, Suite 2-4876, Valley Cottage, NY 10989, USA

Tel: 1-323-984-7526, 323-410-1082; Fax: 1-323-984-7374, 323-908-0457

<http://www.davidpublisher.com>, www.davidpublisher.org

economics.world@davidpublishing.org, economics.world@hotmail.com

